

ATTENZIONE - ATTENTION - ACHTUNG

- VERIFICARE LE MISURE DI INGOMBRO PER POSSIBILE INTERFERENZA SU ALCUNI MODELLI DI MACCHINE
- Please check the overall sizes for possible interferences on some machine models
- Bitte überprüfen sie das ausmass um mögliche interferenzen auf einigen maschinen modellen zu vermeiden

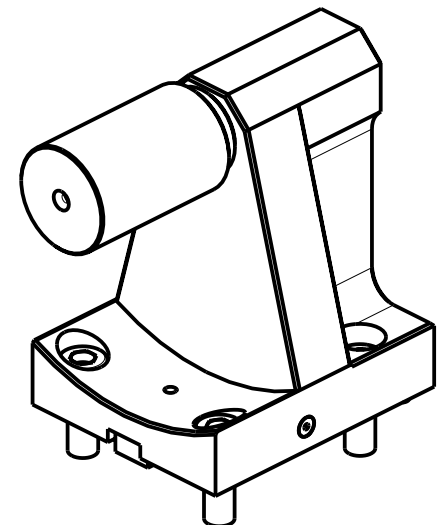

Cod. MT	N°Utensili N° Tools N° Werkzeuge	D	L
0800100	1	38	125
0800100L	1	2"	131.4

BIGLIA
 MOD: B301/445/470/501(Y-S)/510/545/550/565/650/658/1200 - B750/1250 16 ST.

CONTROPUNTA PER CONTROMANDRINO
 Tailstock for subspindle
 Gegenspitz fuer Gegenspindel

Subject to change without notice.

M.T. srl
 Via Casino Albini 480
 Tel. 0541/956034-957884
 Fax 0541/956341
 47842 S. GIOVANNI IN M. (RN)
 e-mail: mtma@mtmarchetti.com
 http://www.mtmarchetti.com

PRODUZIONE MODULI ROTANTI



PAGINA BGL950-1-00