

**ATTENZIONE - ATTENTION - ACHTUNG**

-Su macchine B545/B565/B650 non utilizzare su lato contromandrino.

-On B545/B565/B650 do not use on sub-spindle side.

-Auf B545/B565/B650 Maschinen nicht auf der gegenspindel-seite benutzen.

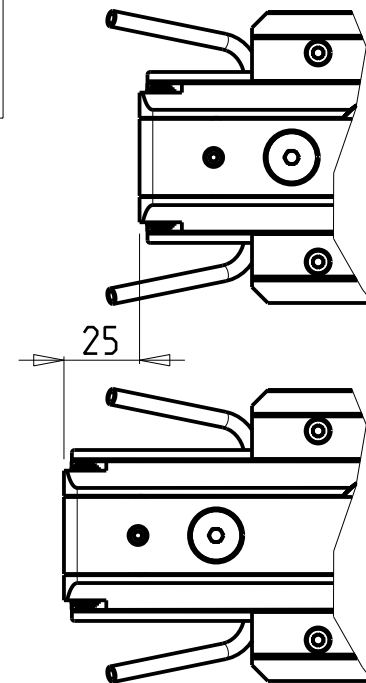
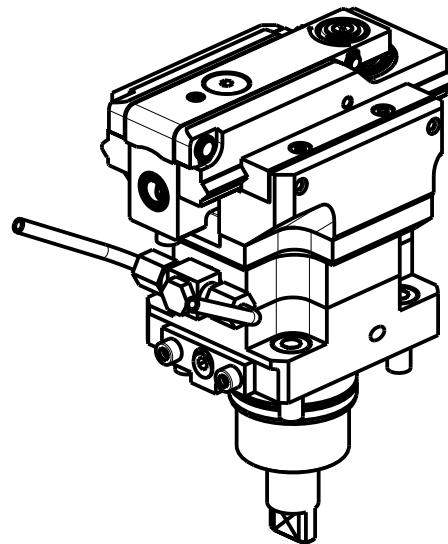

PER UTENSILI STOZZATORI VEDI PAG. TBL400-1-00  
 FOR DRIVEN SLOTTING TOOL CUTTING-TOOLS SEE PAGE TBL400-1-00  
 FÜR NUTENSTOSS-WERKZEUG SCHNEIDWERKZEUGE SIEHE SEITE TBL400-1-00

Cod. MT	I	RPM MAX	Reversibile lato mandrino/contromandrino Reversible sub/main spindle side Umkehrbare Spindel-seite/ Gegenspindel-seite	Lubr. esterna Ext. coolant Aussenkuehlung
BGL0330200	4:1	2400	X	X

**BIGLIA**  
 MOD: B445/470/545/550/565/650/658/1200/446/465/745/765 - B750/1250 16 ST.

MODULO MOTORIZZATO STOZZATORE CORSA 25mm H=100mm  
 Slotting driven tool 25mm stroke H=100mm  
 Keilnutenstossmaschine 25mm Hub H=100mm

**M.T. srl**  
 Via Casino Albini 480  
 Tel. 0541/956034-957884  
 Fax 0541/956341  
 47842 S. GIOVANNI IN M. (RN)  
 e-mail: mtma@mtmarchetti.com  
 http://www.mtmarchetti.com

PRODUZIONE MODULI ROTANTI



PAGINA BGL360-1-11

Subject to change without notice.

03/2018