

Parting & Grooving - Holder
Blade

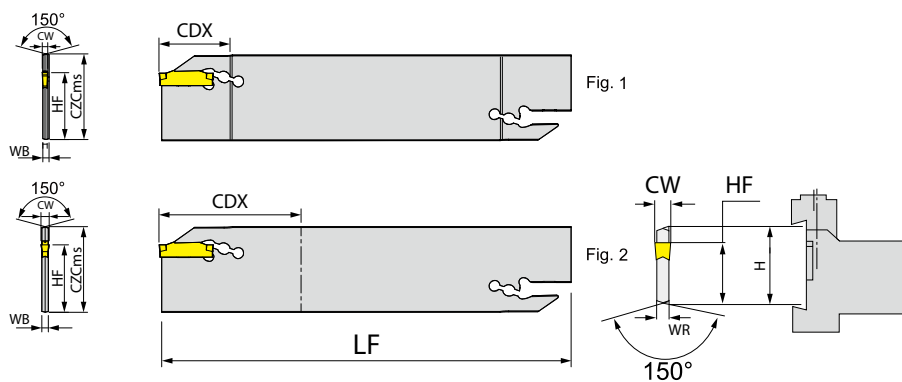

: p. 119 Unit:mm

Designation	EDP 5700..	CZCms	CW	CDX	HF	LF	WB	Insert	Fig
YGB 32 - 2	0058	32	2	25	25	150	2.4	TD.2..	1
YGB 32 - 3	0059	32	3	50	25	150	2.4	TD.3..	2
YGB 32 - 2 - C	● 0226	32	2	25	25	150	2.4	TD.2..	1
YGB 32 - 3 - C	● 0227	32	3	50	25	150	2.4	TD.3..	2

TURNING

PARTING & GROOVING

MILLING

DRILLING

TECHNICAL INFORMATION

Series	Designation	Information	Screw	Ring	Wrench
YGB..	..-32..	Description	-	-	YALA-02
		EDP	-	-	58000027

Parting & Grooving Overview

Parting & Groove Turn Grades



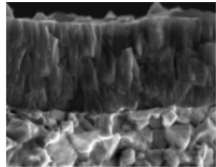
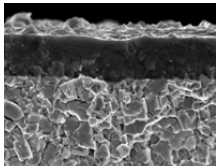









Parting and Grooving Grades		P Steel				M Stainless steel				K Cast iron			N Non Ferrous		S Super Alloy	
		P10	P20	P30	P40	M10	M20	M30	M40	K10	K20	K30	N10	N20	S10	S20
PVD	YG602G (YG602)		602G				602G				602G					602G
	YG603						603									

<p>YG602G (YG602)</p> <p>P20 - P35 M20 - M40 K20 - K40 S15 - S25</p>	<p>PVD - TiAlN</p> 	<p>Universal grade for Parting & Groove Turn</p> <ul style="list-style-type: none"> Ultra Dense PVD Coating with optimal thermal resistance & strength Sub-Micron substrate designed for demanding application YG602G : First Choice for Low Cutting Speed, Soft and Sticky Material with Low Hardness (Gold Color) YG602 : First Choice for General Application (Violet Color)
<p>YG603</p> <p>M30 - M50</p>	<p>PVD - TiAlN</p> 	<p>PVD Parting & Grooving Grade for Stainless Steel</p> <ul style="list-style-type: none"> Ultra high toughness substrate and strong adhesion Excellent cutting edge strength and chipping resistance Stable machinability and tool life for stainless steel

Parting & Grooving Inserts

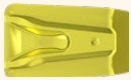
	TD. Series	Inserts TDN, TDP, TDY	2, 3, 4, 5
---	------------	---------------------------------	------------

Parting & Grooving Chipbreakers

Parting & Grooving	-P			<ul style="list-style-type: none"> For Parting & Deep Grooving For Low Feed Rate and Difficult to Cut Materials
	-N			<ul style="list-style-type: none"> For External Parting And Grooving For General Use
Turning & Grooving	-Y			<ul style="list-style-type: none"> For External Turning & Grooving For Medium feed rate
	NEW GL			<ul style="list-style-type: none"> For External, Internal turning and Grooving Face grooving and Face turning For low feed rate
	NEW GM			<ul style="list-style-type: none"> For External, Internal turning and Grooving First choice Face Grooving and Face turning For Medium feed rate
	NEW RG			<ul style="list-style-type: none"> For External, Internal turning and Grooving Full radius Insert for Profiling