

MF ISO Metric Fine Threads DIN 13

- **Metrisches ISO-Feingewinde DIN 13**
- **ISO MÉTRIQUE PAS FINS DIN 13**
- **ISO Metrico passo fine DIN 13**

 Machine taps
Maschinengewindebohrer

- ▶ Coated HSS-PM (Powder Metallurgy) Taps for high-speed tapping on rigid CNC machines or equivalent machines
- ▶ Up to 3 times faster in tapping compared to conventional taps
- ▶ For high-speed synchro tapping, synchro holder for increasing tool life and thread quality is recommended
- ▶ High precision threads

- ▶ Beschichtete HSS-PM-Gewindebohrer zum Hochgeschwindigkeitsgewindebohren auf starren CNC-Maschinen oder gleichwertige Maschinen
- ▶ Bis zu dreimal schnelleres Gewindeschneiden als bei herkömmlichen Gewindebohrern
- ▶ Beim Hochgeschwindigkeits-Gewindebohren wird die Verwendung eines Synchrofußers zur Erhöhung der Werkzeugstandzeit und der Gewindequalität empfohlen
- ▶ Hoch präzise Gewinde

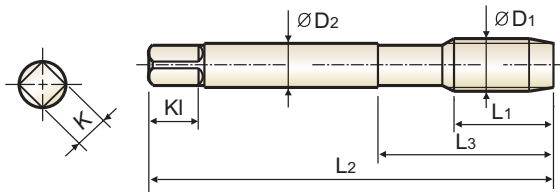
Hole type

2.5×D

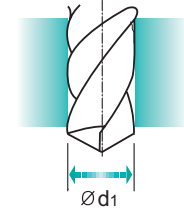
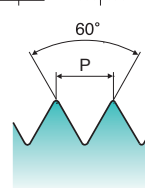
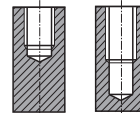

Material groups: **GS** HSS PM DIN 374 6HX 60° C R45 TiN p.B74



Unit : mm

SIZE	Pitch	EDP No.	Thread Length	Overall Length	Neck Length	Shank Diameter	Square Size	Square Length	No. of Flute	Tapping Drill Diameter
ØD1	P	TiN	L1	L2	L3	ØD2	K	KI	Z	Ød1
M8 × 1.0		TTS32376	10	90	36	6	4.9	8	3	7.0
M10 × 1.25		TTS32436	13	100	40	7	5.5	8	3	8.75
M10 × 1.0		TTS32446	10	90	40	7	5.5	8	3	9.0
M12 × 1.25		TTS32526	13	100	40	9	7	10	3	10.75
M12 × 1.5		TTS32516	15	100	40	9	7	10	3	10.5
M14 × 1.5		TTS32556	15	100	40	11	9	12	3	12.5
M16 × 1.5		TTS32616	15	100	40	12	9	12	3	14.5
M18 × 1.5		TTS32676	17	110	44	14	11	14	4	16.5
M20 × 1.5		TTS32726	17	125	50	16	12	15	4	18.5

▶ Coating (TiAlN) is available on your request.

◎ : Excellent ○ : Good

ISO	P										M					K						
	Non-alloy steel					Low alloy steel					High alloyed steel, and tool steel					Stainless steel			Grey cast iron		Nodular cast iron	
Material Description	1	2	3	4	5	6	7	8	9	10	11	12	13	14	15	16	17	18	19	20		
VDI 3323	1	2	3	4	5	6	7	8	9	10	11	12	13	14	15	16	17	18	19	20		
HRC	13	13	25	28	32	10	29	32	38	15	35	15	23	10	10	26	3	25	21	21		
HB	125	190	250	270	300	180	275	300	350	200	325	200	240	180	180	260	160	250	130	230		
Recommended	◎	◎	◎	◎	◎	◎	◎					◎	◎	○	○		◎					

ISO	N					S										H					
	Aluminum-wrought alloy		Aluminum-cast, alloyed			Copper and Copper Alloys (Bronze / Brass)			Non Metallic Materials		Heat Resistant Super Alloys					Titanium Alloys		Hardened steel	Chilled Cast Iron	Hardened Cast Iron	
Material Description	21	22	23	24	25	26	27	28	29	30	31	32	33	34	35	36	37	38	39	40	41
VDI 3323	21	22	23	24	25	26	27	28	29	30	31	32	33	34	35	36	37	38	39	40	41
HRC											15	30	25	38	34			55	60	42	55
HB	60	100	75	90	130	110	90	100			200	280	250	350	320	400Rm	1050Rm	550	630	400	550
Recommended			◎	◎	◎	◎															

SELECTION GUIDE



HSS-PM SYNCHRO TAP

For High Speed Tapping on Rigid CNC Machine



Please visit globalyg1.com/mat for material search

◎ : Excellent ○ : Good

Recommended cutting conditions : p.B74

HOLE TYPE		Max. 2.5xD Blind Hole	Max. 3.0xD Through Hole			
TOOL MATERIAL		HSS-PM				
CHAMFER LEAD ACC. TO DIN2197		C	B			
FLUTE TYPE		Spiral Flute	Spiral Point			
SPIRAL FLUTE ANGLE		R45	-			
SERIES	M	DIN371/376	TTS31 (p.B60)	TTS33 (p.B62)		
		DIN352				
		DIN357/LONG				
	MF	DIN374		TTS32 (p.B61)		TTS34 (p.B63)
		DIN2181				
	UNC	DIN371/376				
		DIN351				
	UNF	DIN371/374				
		DIN2181				
	BSW	DIN2182/2183				
		DIN351				
	G (BSP)	DIN5156/5157				
EG-M	DIN371/376					
EG-UNC	DIN371/376					
EG-UNF	DIN371/374					
SURFACE TREATMENT		TiN		TiN		
MODEL						

ISO	VDI 3323	Material Description	Composition / Structure / Heat Treatment	HB	HRc					
P	1	Non-alloy steel	About 0.15% C Annealed	125		◎	◎	◎	◎	
	2		About 0.45% C Annealed	190	13	◎	◎	◎	◎	
	3		About 0.45% C Quenched & Tempered	250	25	◎	◎	◎	◎	
	4		About 0.75% C Annealed	270	28	◎	◎	◎	◎	
	5		About 0.75% C Quenched & Tempered	300	32					
	6	Low alloy steel	Annealed	180	10	◎	◎	◎	◎	
	7		Quenched & Tempered	275	29	◎	◎	◎	◎	
	8		Quenched & Tempered	300	32					
	9		Quenched & Tempered	350	38					
	10		High alloyed steel, and tool steel	Annealed	200	15				
	11			Quenched & Tempered	325	35				
M	12	Stainless steel	Ferritic / Martensitic Annealed	200	15	◎	◎	◎	◎	
	13		Martensitic Quenched & Tempered	240	23	◎	◎	◎	◎	
	14		Austenitic	180	10	○	○	○	○	
K	15	Grey cast iron	Pearlitic / ferritic	180	10	○	○	○	○	
	16		Pearlitic (Martensitic)	260	26					
	17	Nodular cast iron	Ferritic	160	3	◎	◎	◎	◎	
	18		Pearlitic	250	25					
	19	Malleable cast iron	Ferritic	130						
	20		Pearlitic	230	21					
N	21	Aluminum-wrought alloy	Not Curable	60						
	22		Curable Hardened	100						
	23	Aluminum-cast, alloyed	≤ 12% Si, Not Curable	75		◎	◎	◎	◎	
	24		≤ 12% Si, Curable Hardened	90		◎	◎	◎	◎	
	25		> 12% Si, Not Curable	130		◎	◎	◎	◎	
	26		Cutting Alloys, PB>1%	110		◎	◎	◎	◎	
	27	Copper and Copper Alloys (Bronze / Brass)	CuZn, CuSnZn (Brass)	90						
	28		CuSn, lead-free copper and electrolytic copper	100		○	○	○	○	
	29	Non Metallic Materials	Duroplastic, Fiber Reinforced Plastic							
	30	Rubber, Wood, etc.								
S	31	Heat Resistant Super Alloys	Fe Based Annealed	200	15					
	32		Cured	280	30					
	33		Annealed	250	25					
	34		Ni or Co Based Cured	350	38					
	35		Cast	320	34					
	36	Titanium Alloys	Pure Titanium	400 Rm						
	37		Alpha + Beta Alloys Hardened	1050 Rm						
H	38	Hardened steel	Hardened	550	55					
	39		Hardened	630	60					
	40	Chilled Cast Iron	Cast	400	42					
	41	Hardened Cast Iron	Hardened	550	55					



THREAD
MILL

SYNCHRO
TAP

PRIME
TAP

COMBO
TAP

YG TAP
STEEL

YG TAP CHIP
BREAKER

YG TAP
INOX

YG TAP
CAST IRON

YG TAP
HARDENED
STEEL

YG TAP
Ti Ni

YG TAP
ALU

YG TAP
FORMING

YG TAP
GENERAL

PIPE TAP

STI TAP

NUT TAP

TECHNICAL
DATA

					TTS31,TTS32	TTS33,TTS34	TKS35,TKS36	TTS37,TTS38	TTS39	
ISO	VDI 3323	Material Description	HB	HRC	Vc (m/min.)					
P	1	Non-alloy steel	125		41-46	41-46	41-46	41-46	30-35	
	2		190	13	41-46	41-46	41-46	41-46	41-46	
	3		250	25	35-40	35-40	35-40	35-40	35-40	
	4		270	28	28-33	28-33	28-33	28-33	28-33	
	5		300	32						
	6	Low alloy steel	180	10	28-33	28-33	28-33	28-33	28-33	
	7		275	29	28-33	28-33	28-33	28-33	28-33	
M	12	Stainless steel	200	15	18-23	18-23		18-23	18-23	
	13		240	23	13-18	13-18		13-18	13-18	
	14		180	10	10-14	10-14		10-14	10-14	
K	15	Grey cast iron	180	10	28-33	28-33	28-33			
	16		260	26			28-33			
	17	Nodular cast iron	160	3	28-33	28-33	28-33			
	18		250	25			28-33			
	19	Malleable cast iron	130				28-33			
20	230		21			28-33				
N	21	Aluminum-wrought alloy	60					28-33	28-33	
	22		100				28-33	28-33		
	23	Aluminum-cast, alloyed	75		41-46	41-46	30-35	41-46	41-46	
	24		90		41-46	41-46	30-35	41-46	41-46	
	25		130		30-35	30-35	30-35	30-35	30-35	
	26		Copper and Copper Alloys (Bronze / Brass)	110		45-50	45-50			
	27			90						
	28			100		25-30	25-30		25-30	25-30

					TTS41-IC	TTS42-RCP	TKS43-IC	TKS44-RCP	TTS45-RCP	
ISO	VDI 3323	Material Description	HB	HRC	Vc (m/min.)					
P	1	Non-alloy steel	125		41-57	41-57	41-57	41-57	41-57	
	2		190	13	41-57	41-57	41-57	41-57	41-57	
	3		250	25	35-50	35-50	35-50	35-50	35-50	
	4		270	28	28-41	28-41	28-41	28-41	28-41	
	5		300	32						
	6	Low alloy steel	180	10	28-41	28-41	28-41	28-41	28-41	
	7		275	29	28-41	28-41	28-41	28-41	28-41	
M	12	Stainless steel	200	15	18-28	18-28			18-28	
	13		240	23	13-22	13-22			13-22	
	14		180	10	10-17	10-17			10-17	
K	15	Grey cast iron	180	10	28-41	28-41	28-41	28-41		
	16		260	26			28-41	28-41		
	17	Nodular cast iron	160	3	28-41	28-41	28-41	28-41		
	18		250	25			28-41	28-41		
	19	Malleable cast iron	130				28-41	28-41		
20	230		21			28-41	28-41			
N	21	Aluminum-wrought alloy	60						28-41	
	22		100					28-41		
	23	Aluminum-cast, alloyed	75		41-57	41-57	30-43	30-43	41-57	
	24		90		41-57	41-57	30-43	30-43	41-57	
	25		130		30-43	30-43	30-43	30-43	30-43	
	26		Copper and Copper Alloys (Bronze / Brass)	110		45-62	45-62			
	27			90						
	28			100		25-37	25-37		25-37	25-37

SURFACE TREATMENT AND COATING

The applied High Speed Steels holds a grant of good wear resistance and toughness. Therefore YG-1 normally delivers taps with bright and unfinished surface. For certain materials, various surface treatments provide higher advantage in machining.

STEAM TEMPERED - VAP

Steam Tempered is a Fe₃O₄-oxyd-coating which reduces friction between the tool and workpiece, also preventing cold welding.

NITRIDING - NI

Recommend surface treatment for machining materials that affect wear abrasion, such as grey cast iron, alu-alloys with high Si-percentages (more than 10%).

Below are the various surface treatments for excellent finish surfaces suitable for many applications. The surface treatments are produced and developed within the company.

X-COATING

YG-1's High Performance Coating for high heat and wear resistance

TiN-COATING

TiN-coating yields a hardness of approx. 2,300 HV and also a heat resistant up to approx. 600°C. The current coating is an excellent all-round coating for normal applications. (Colour : Golden Coefficient of friction against steel : 0.4)

TiCN-COATING

TiCN takes place of TiN when the conditions require the coating to have a different hardness and toughness. The TiCN brings advantages for machining very difficult steels or cutting interrupted bores. The TiCN-coating has a hardness of approx. 3,000 HV, but is heat resistance only holds up to approx. 400°C, meaning that the TiCN needs an excellent cooling system for a long service life. (Colour : Blue-Grey Coefficient of friction against steel : 0.4)

TiAlN-COATING

A special coating for machining abrasive materials such as grey cast iron, alu-alloys with silicon, fiber reinforced plastics, etc., or machining at high temperatures with insufficient cooling, or at high speeds $\geq 600\text{m/min}$. TiAlN has a hardness of approx. 3,000 HV and is heat resistant up to approx. 800°C. (Colour : Violet-Grey Coefficient of friction against steel : 0.4)

HARDSLICK-COATING

Hardslick combines the advantages of an extremely hard, thermally stable TiAlN-coating with the sliding and lubricating properties of an outer WC/C(Tungsten carbide/carbon)-coating in a novel way. The Hardslick coating has a hardness of approx. 3,000 HV and is temperature-resistant up to approx. 800°C. (Colour : Violet-Grey Coefficient of friction against steel : 0.2)

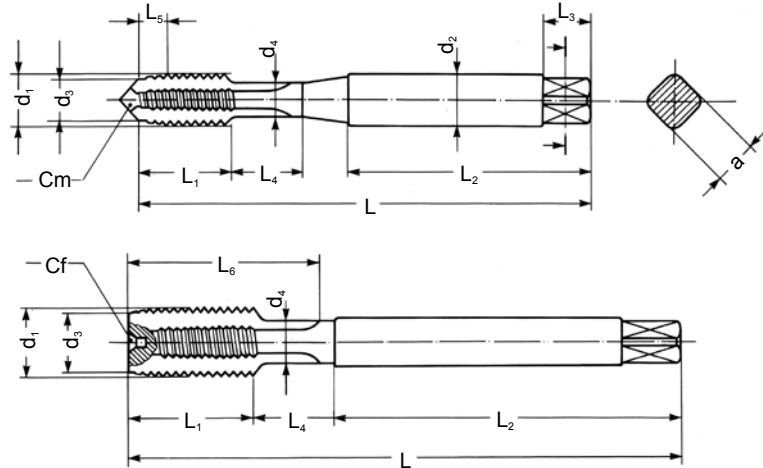
TAPS TERMINOLOGY
FACHAUSDRÜCKE BEI GEWINDEBOHRERN (Terminologie)

d_1 Major diameter
 d_2 Shank diameter
 d_3 Chamfer diameter
 d_4 Neck diameter
 L Total length
 L_1 Thread length
 L_2 Shank length
 L_3 Square length
 L_4 Neck length
 L_5 Chamfer length
 L_6 Flutes length
 a Square
 Cm Center male
 Cf Center female

d_1 Nenn Aussendurchmesser
 d_2 Schaftdurchmesser
 d_3 Anschnittdurchmesser
 d_4 Bunddurchmesser
 L Gesamtlänge
 L_1 Gewindelänge
 L_2 Schaftlänge
 L_3 Vierkantlänge
 L_4 Bundlänge
 L_5 Anschnittlänge
 L_6 Nutenlänge
 a Vierkantmaß β
 Cm Mittelpunkt des Aussengewindes
 Cf Mittelpunkt des Innengewindes

d_1 Diamètre externe nominal
 d_2 Diamètre de la queue
 d_3 Diamètre de l'entrée
 d_4 Diamètre de la collerette de dégagement
 L Longueur totale
 L_1 Longueur de la partie filetée
 L_2 Longueur de la queue
 L_3 Longueur du carré
 L_4 Longueur de la collerette de dégagement
 L_5 Longueur de l'entrée
 L_6 Longueur des goujures
 a Carré
 Cm Centre mâle
 Cf Centre femelle

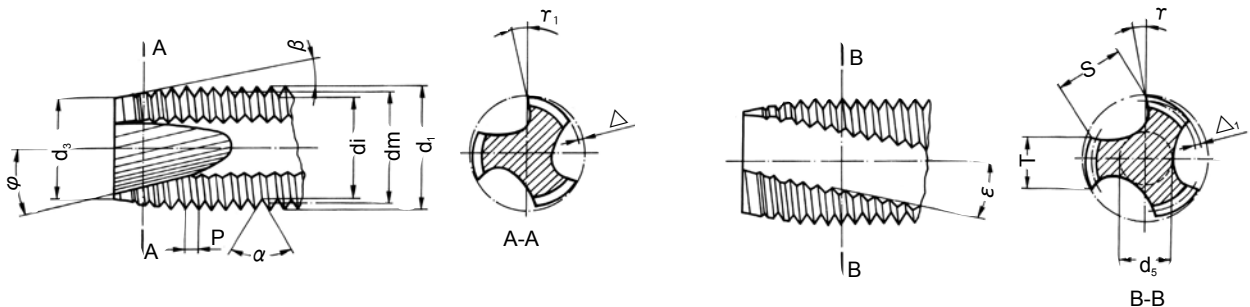

d_1 Major diameter
 dm Flank diameter
 di Minor diameter
 d_3 Chamfer diameter
 P Pitch
 a Flank angle
 β Chamfer angle
 φ Gun nose angle
 r Gun nose rake angle in front
 Δ Chamfer relief
 Δ_1 Pitch diameter relief on the land
 τ Rake angle
 T Width of land
 S Flute width
 d_5 Web thickness
 ϵ Angle of spiral flute

d_1 Nenn Aussendurchmesser
 dm Flankendurchmesser
 di Kerndurchmesser
 d_3 Anschnittdurchmesser
 P Steigung
 a Flankenwinkel
 β Anschnittwinkel
 φ Schälsschnittwinkel
 r Schälsschnitt-Spanwinkel
 r_1 Schälsschnitt-Spanwinkel
 Δ Hinterschliff am Anschnitt
 Δ_1 Flankenhinterschliff auf Zahnbreite
 τ Spanwinkel
 T Zahnstollenbreite
 S Nutenbreite
 d_5 Seelendicke
 ϵ Spiralwinkel

d_1 Diamètre externe nominal
 dm Diamètre moyen
 di Diamètre interne
 d_3 Diamètre de l'entrée
 P Pas
 a Angle du filet
 β Demi-angle du cône d'entrée
 φ Angle de l'entrée GUN
 r Angle de coupe sur l'entrée GUN
 Δ Détalonnage sur l'entrée
 Δ_1 Détalonnage sur le filet
 τ Angle de coupe frontale
 T Largeur des dents
 S Largeur des goujures
 d_5 Diamètre de l'âme
 ϵ Angle d'hélice des goujures

**RECOMMENDED TAP DRILL SIZE
EMPFOHLENE KERNLOCHMASSE**

Unit : mm

Metric-ISO threads coarse pitch				Metric-ISO threads fine pitch				Metric-ISO threads fine pitch			
M	Pitch	Maximum core dia.	Drill size	MF	Pitch	Maximum core dia.	Drill size	MF	Pitch	Maximum core dia.	Drill size
1	0.25	0.785	0.75	2.5	0.35	2.221	2.15	25	2.00	23.210	23.00
1.1	0.25	0.885	0.85	3	0.35	2.271	2.65	26	1.50	24.676	24.50
1.2	0.25	0.985	0.95	3.5	0.35	3.221	3.15	27	1.00	26.153	26.00
1.4	0.30	1.160	1.10	4	0.50	3.599	3.50	27	1.50	25.676	25.50
1.6	0.35	1.321	1.25	4.5	0.50	4.099	4.00	27	2.00	25.210	25.00
1.7	0.35	1.346	1.30	5	0.50	4.599	4.50	28	1.00	27.153	27.00
1.8	0.35	1.521	1.45	5.5	0.50	5.099	5.00	28	1.50	26.676	26.50
2	0.40	1.679	1.60	6	0.75	5.378	5.20	28	2.00	26.210	26.00
2.2	0.45	1.838	1.75	7	0.75	6.378	6.20	30	1.00	29.153	29.00
2.3	0.40	1.920	1.90	8	0.75	7.378	7.20	30	1.50	28.676	28.50
2.5	0.45	2.138	2.05	8	1.00	7.153	7.00	30	2.00	28.210	28.00
2.6	0.45	2.176	2.10	9	0.75	8.378	8.20	30	3.00	27.252	27.00
3	0.50	2.599	2.50	9	1.00	8.153	8.00	32	1.50	30.675	30.50
3.5	0.60	3.010	2.90	10	0.75	9.378	9.20	32	2.00	30.210	30.00
4	0.70	3.422	3.30	10	1.00	9.153	9.00	33	1.50	31.676	31.50
4.5	0.75	3.878	3.70	10	1.25	8.912	8.80	33	2.00	31.210	31.00
5	0.80	4.334	4.20	11	0.75	10.378	10.20	33	3.00	30.252	30.00
6	1.00	5.153	5.00	11	1.00	10.153	10.00	35	1.50	33.676	33.50
7	1.00	6.153	6.00	12	1.00	11.153	11.00	36	1.50	34.676	34.50
8	1.25	6.912	6.80	12	1.25	10.912	10.80	36	2.00	34.210	34.00
9	1.25	7.912	7.80	12	1.50	10.676	10.50	36	3.00	33.252	33.00
10	1.50	8.676	8.50	14	1.00	13.153	13.00	38	1.50	36.676	36.50
11	1.50	9.676	9.50	14	1.25	12.912	12.80	39	1.50	37.676	37.50
12	1.75	10.441	10.20	14	1.50	12.676	12.50	39	2.00	37.210	37.00
14	2.00	12.210	12.00	15	1.00	14.153	14.00	39	3.00	36.252	36.00
16	2.00	14.210	14.00	15	1.50	13.676	13.50	40	1.50	38.676	38.50
18	2.50	15.744	15.50	16	1.00	15.153	15.00	40	2.00	38.210	38.00
20	2.50	17.744	17.50	16	1.50	14.676	14.50	40	3.00	37.252	37.00
22	2.50	19.744	19.50	17	1.00	16.153	16.00	42	1.50	40.676	40.50
24	3.00	21.252	21.00	17	1.50	15.676	15.50	42	2.00	40.210	40.00
27	3.00	24.252	24.00	18	1.00	17.153	17.00	42	3.00	39.252	39.00
30	3.50	26.771	26.50	18	1.50	16.676	16.50	45	1.50	43.676	43.50
33	3.50	29.771	29.50	18	2.00	16.210	16.00	45	2.00	43.210	43.00
36	4.00	32.270	32.00	20	1.00	19.153	19.00	45	3.00	42.252	42.00
39	4.00	35.270	35.00	20	1.50	18.676	18.50	48	1.50	46.676	46.50
42	4.50	37.799	37.50	20	2.00	18.210	18.00	48	2.00	46.210	46.00
45	4.50	40.799	40.50	22	1.00	21.153	21.00	48	3.00	45.252	45.00
48	5.00	43.297	43.00	22	1.50	20.676	20.50	50	1.50	48.676	48.50
52	5.00	47.297	47.00	22	2.00	20.210	20.00	50	2.00	48.210	48.00
56	5.50	50.796	50.50	24	1.00	23.153	23.00	50	3.00	47.252	47.00
60	5.50	54.796	54.50	24	1.50	22.676	22.50	52	1.50	50.676	50.50
64	6.00	58.305	58.00	24	2.00	22.210	22.00	52	2.00	50.210	50.00
68	6.00	62.305	62.00	25	1.00	24.153	24.00	52	3.00	49.252	49.00
				25	1.50	23.676	23.50				



Unit : mm

	American Unified coarse threads				American Unified fine threads			
	UNC	T.P.I	Maximum core dia.	Drill size	UNF	T.P.I	Maximum core dia.	Drill size
	#1	64	1.585	1.50	#0	80	1.306	1.30
	#2	56	1.872	1.80	#1	72	1.613	1.60
	#3	48	2.146	2.10	#2	64	1.913	1.90
COMBO TAPS	#4	40	2.385	2.30	#3	56	2.197	2.10
	#5	40	2.697	2.60	#4	48	2.459	2.40
	#6	32	2.896	2.85	#5	44	2.741	2.70
YG TAP GENERAL	#8	32	3.528	3.50	#6	40	3.012	3.00
	#10	24	3.950	3.90	#8	36	3.597	3.50
	#12	24	4.590	4.50	#10	32	4.168	4.10
YG TAP STEEL	1/4"	20	5.250	5.20	#12	28	4.717	4.70
	5/16"	18	6.680	6.60	1/4"	28	5.563	5.50
	3/8"	16	8.082	8.00	5/16"	24	6.995	6.90
YG TAP HARDENED	7/16"	14	9.441	9.40	3/8"	24	8.565	8.50
	1/2"	13	10.881	10.75	7/16"	20	9.947	9.90
YG TAP INOX	9/16"	12	12.301	12.25	1/2"	20	11.524	11.50
	5/8"	11	13.693	13.50	9/16"	18	12.969	12.90
	3/4"	10	16.624	16.50	5/8"	18	14.554	14.50
YG TAP CAST IRON	7/8"	9	19.520	19.50	3/4"	16	17.546	17.50
	1"	8	22.344	22.25	7/8"	14	20.493	20.50
	1*1/8"	7	25.082	25.00	1"	12	23.363	23.25
YG TAP ALU	1*1/4"	7	28.258	28.25	1*1/8"	12	26.538	26.50
	1*3/8"	6	30.851	30.75	1*1/4"	12	29.713	29.50
	1*1/2"	6	34.026	34.00	1*3/8"	12	32.888	32.70
YG TAP Ti Ni	1*3/4"	5	39.560	39.50	1*1/2"	12	36.063	36.00
	2"	4.5	45.367	45.25				

	Whitworth threads B.S.W.				Whitworth pipe thread BSP.PI			
	BSW	T.P.I	Maximum core dia.	Drill size	G(BSP)	T.P.I	Maximum core dia.	Drill size
	3/32"	48	1.910	1.80	1/8"	28	8.848	8.80
	1/8"	40	2.590	2.50	1/4"	19	11.890	11.80
	5/32"	32	3.211	3.10	3/8"	19	15.395	15.25
PIPE TAPS	3/16"	24	3.743	3.60	1/2"	14	19.172	19.00
	7/32"	24	4.538	4.40	5/8"	14	21.128	21.00
	1/4"	20	5.224	5.10	3/4"	14	24.658	24.50
	5/16"	18	6.661	6.50	7/8"	14	28.418	28.25
	3/8"	16	8.052	7.90	1"	11	30.931	30.75
	7/16"	14	9.379	9.30	1*1/8"	11	35.579	35.50
	1/2"	12	10.610	10.50	1*1/4"	11	39.592	39.50
	9/16"	12	12.176	12.00	1*3/8"	11	42.005	42.00
	5/8"	11	13.598	13.50	1*1/2"	11	45.485	45.20
	3/4"	10	16.538	16.50	1*5/8"	11	49.670	49.60
	7/8"	9	19.411	19.25	1*3/4"	11	51.428	51.40
	1"	8	22.185	22.00	2"	11	57.296	57.20
	1*1/8"	7	24.879	24.75	2*1/4"	11	63.392	63.30
	1*1/4"	7	28.054	27.75	2*3/8"	11	67.080	67.00
	1*3/8"	6	30.555	30.50	2*1/2"	11	72.866	72.80
	1*1/2"	6	33.730	33.50	2*3/4"	11	79.216	79.10
	1*5/8"	5	35.921	35.50	3"	11	85.566	85.50
	1*3/4"	5	39.096	39.00	3*1/4"	11	91.662	91.50
	1*7/8"	4.5	41.648	41.50	3*1/2"	11	98.012	98.00
	2"	4.5	44.823	44.50	3*3/4"	11	104.362	104.00
	2*1/4"	4	50.420	50.00	4"	11	110.712	110.50
	2*1/2"	4	56.770	56.50				
	2*3/4"	3.5	62.108	62.00				
	3"	3.5	68.459	68.50				