



SHRINK FIT HOLDER

SFH

SHRINK FIT HOLDER

DIN 69871-SK

SCHRUMPFUTTER
MANDRIN DE FRETAGE
MADRINI PER CALLETAMENTO A CALDO
PORTAHERRAMIENTAS DE COMPRESION POR CALOR



FIG.1

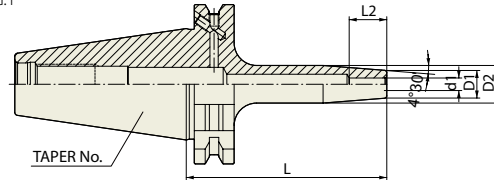
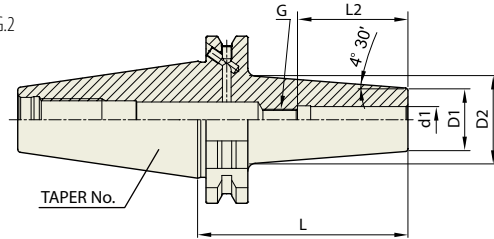

FIG.2



Unit : mm

TAPER No.	MODEL No.	EDP No.	d1	D1	D2	L	L2	G	FIG.	WEIGHT (kg)
30	SK30AD/B-SFH3-60	P2771308	3	11	15	60	10	-	1	0.40
	SK30AD/B-SFH4-60	P2771309	4	11	15	60	12	-	1	0.40
	SK30AD/B-SFH5-60	P2771310	5	11	15	60	15	-	1	0.40
	SK30AD/B-SFH6-60	P2771311	6	21	27	60	36	M5×0.8	2	0.40
	SK30AD/B-SFH8-60	P2771312	8	21	27	60	36	M6×1.0	2	0.40
	SK30AD/B-SFH10-80	P2771313	10	24	32	80	42	M8×1.0	2	0.40
	SK30AD/B-SFH12-80	P2771314	12	24	32	80	47	M10×1.0	2	0.42
	SK30AD/B-SFH14-80	P2771315	14	27	34	80	47	M10×1.0	2	-
	SK30AD/B-SFH16-80	P2771316	16	27	34	80	50	M12×1.0	2	0.42
	SK30AD/B-SFH18-80	P2771317	18	33	42	80	50	M12×1.0	2	-
40	SK30AD/B-SFH20-90	P2771318	20	33	42	90	52	M16×1.0	2	0.44
	SK40AD/B-SFH3-80	P2771301	3	11	15	80	10	-	1	1.00
	SK40AD/B-SFH4-80	P2771302	4	11	15	80	12	-	1	1.00
	SK40AD/B-SFH5-80	P2771303	5	11	15	80	15	-	1	1.00
	SK40AD/B-SFH6-80	P2554058	6	21	27	80	36	M5×0.8	2	1.10
	SK40AD/B-SFH6-160	P2771304	6	21	27	160	36	M5×0.8	2	1.15
	SK40AD/B-SFH8-80	P2600009	8	21	27	80	36	M6×1.0	2	1.11
	SK40AD/B-SFH8-160	P2771305	8	21	27	160	36	M6×1.0	2	1.15
	SK40AD/B-SFH10-80	P2554052	10	24	32	80	42	M8×1.0	2	1.10
	SK40AD/B-SFH10-160	P2771306	10	24	32	160	42	M8×1.0	2	1.15
	SK40AD/B-SFH12-80	P2600008	12	24	32	80	47	M10×1.0	2	1.10
	SK40AD/B-SFH12-160	P2771307	12	24	32	160	47	M10×1.0	2	1.15
	SK40AD/B-SFH14-80	P2771319	14	27	34	80	47	M10×1.0	2	1.20
	SK40AD/B-SFH14-160	P2771320	14	27	34	160	47	M10×1.0	2	1.50
	SK40AD/B-SFH16-80	P2554054	16	27	34	80	50	M12×1.0	2	1.20
	SK40AD/B-SFH16-160	P2554053	16	27	34	160	50	M12×1.0	2	1.50
	SK40AD/B-SFH18-80	P2771321	18	33	42	80	50	M12×1.0	2	1.30
	SK40AD/B-SFH18-160	P2771322	18	33	42	160	50	M12×1.0	2	1.60
	SK40AD/B-SFH20-80	P2554056	20	33	42	80	52	M16×1.0	2	1.40
	SK40AD/B-SFH20-160	P2554055	20	33	42	160	52	M16×1.0	2	1.70
SK40AD/B-SFH25-90	P2771323	25	44	53	90	58	M16×1.0	2	1.70	
SK40AD/B-SFH25-160	P2771324	25	44	53	160	58	M16×1.0	2	2.00	

▶ CAT(ANSI B5.50) taper and Inch type products are available.

▶ Without balancing screw.

▶ NEXT PAGE

SHRINK FIT HOLDER

High Precision I.D Run-out : $\leq 0.003\text{mm}$

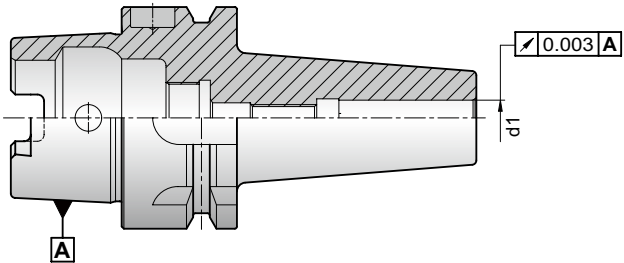

- Less than 0.003mm of Tool Holder accuracy at I.D

Strong and Consistent Torque Power

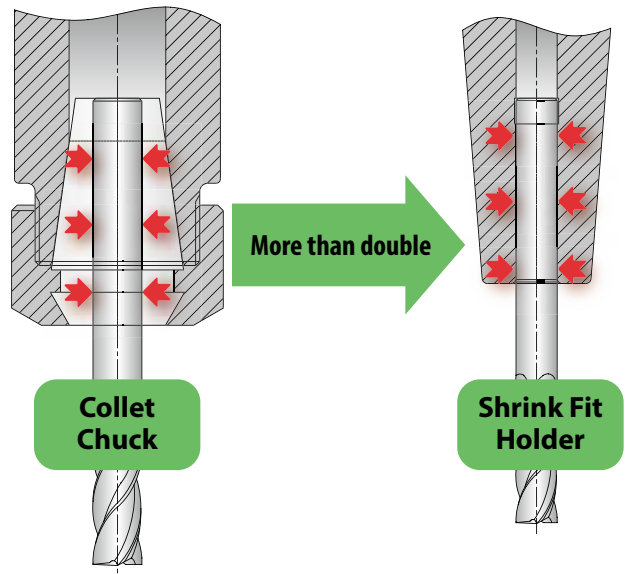

- Achieving strong torque power by integration of chuck and tool

Deep hole Machining

Collet Chuck

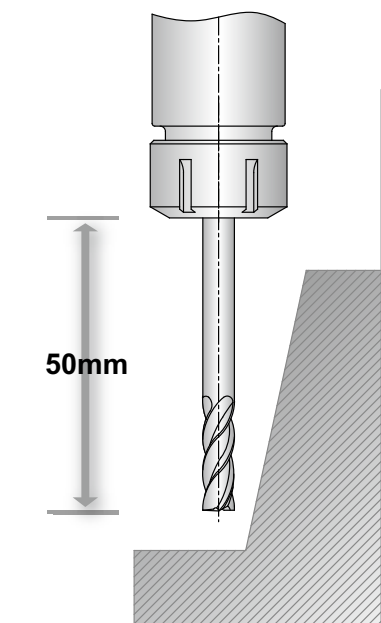

Shrink Fit Holder

More favorable in deep hole machining

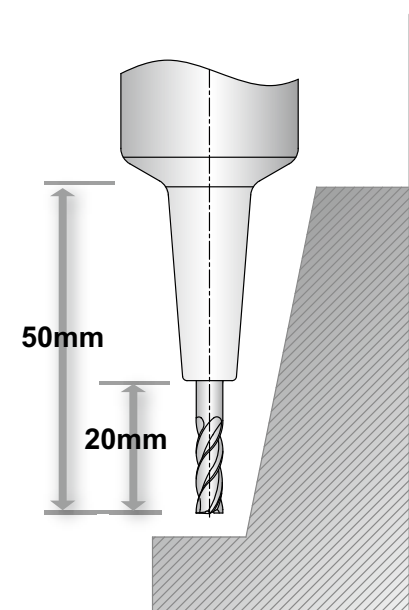

- Suitable for High-Speed precision deep hole machining

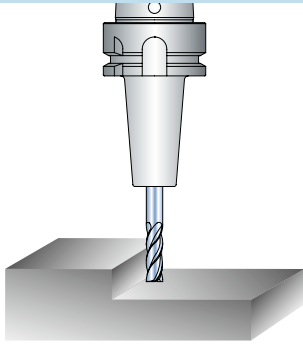
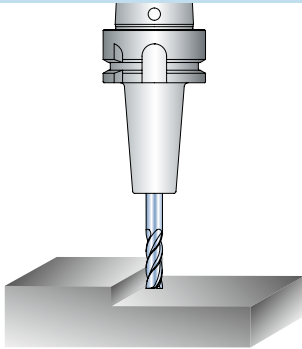
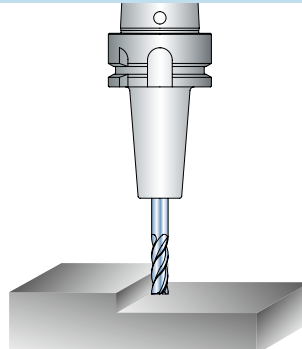
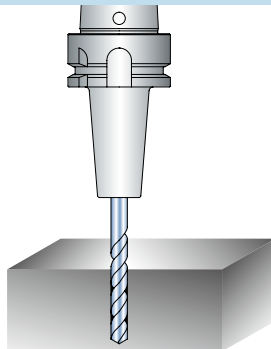
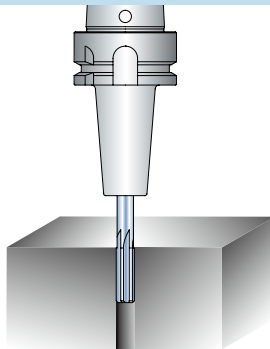
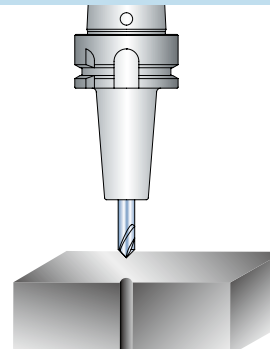
APPLICATION		
Rough Milling 	Finish Milling 	High-Speed Cutting 
Drilling 	Reaming 	Countersinking 

Shank Type of Cutting Tool

Straight shank



One weldon flat shaft type



• One Weldon flat shaft type tool is usable, but there is a possibility that the I.D of shrink fit holder may be deformed.

Material of Cutting Tool

CARBIDE
TOOL

HSS
TOOL

OK

NO

TECHNICAL DATA : SHANK STANDARD

DIN 69871-SK

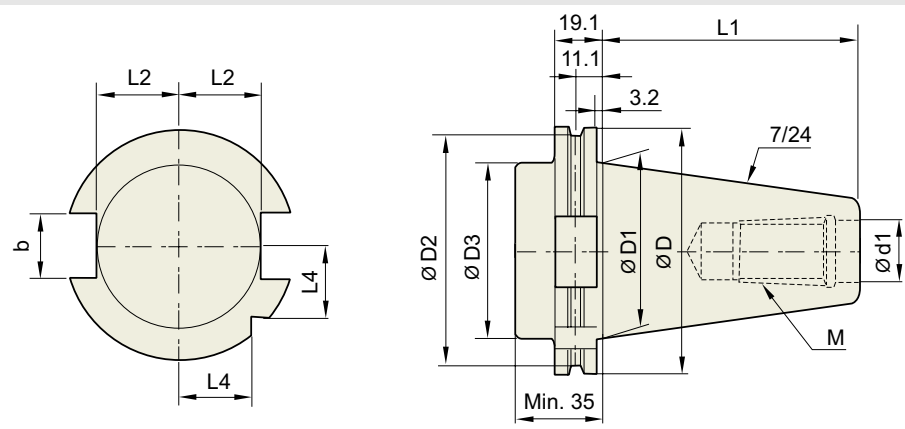

Unit : mm

TAPER No.	ØD	ØD1	ØD2	ØD3	Ød1	L1	L2	L3	L4	b	M
SK30	50	31.75	44.3	45	13	47.8	16.4	19	15	16.1	M12×1.75
SK40	63.55	44.45	56.25	50	17	68.4	22.8	25	18.5	16.1	M16×2.0
SK50	97.5	69.85	91.25	80	25	101.75	35.5	37.7	30	25.7	M24×3.0

JIS B6339/ MAS 403-BT

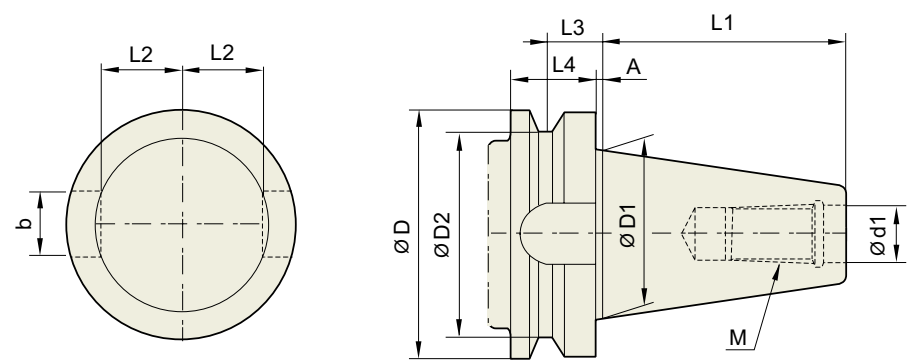

Unit : mm

TAPER No.	ØD	ØD1	ØD2	Ød13.	L1	L2	L3	L4	A	b	M
BT30	46	31.75	38	12.5	48.4	16.3	13.6	20	2	16.1	M12×1.75
BT40	63	44.45	53	17	65.4	22.6	16.6	25	2	16.1	M16×2
BT50	100	69.85	85	25	101.8	35.4	23.2	35	3	25.7	M24×3
BT60	155	107.95	135	31	161.8	60.1	28.2	45	3	25.7	M30×3.5

MODEL NUMBERING SYSTEM & SURFACE FINISH

Model Numbering System

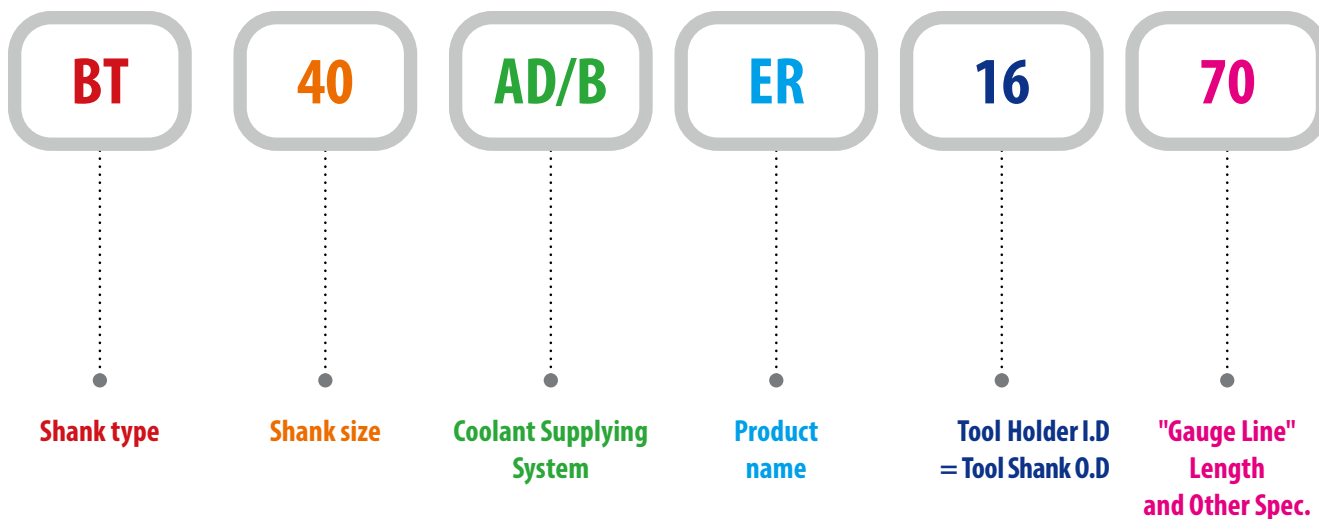

Surface Finish

