

**POWER MILLING CHUCK**

**DIN 228-MTA**

FRÄSERSPANNFUTTER  
MANDRIN PORTE FRAISE  
MANDRINI PORTA FRESA  
PORTAHERRAMIENTAS PARA FRESADO

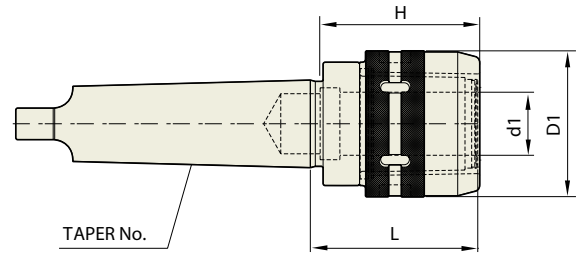

Unit : mm

TAPER No.	MODEL No.	EDP No.	d1	D1	L	H	WEIGHT (kg)
4	MTA4-C32	P2546122	32	72	98	85	2.57
5	MTA5-C32	P2546123	32	72	85	100	3.06
	MTA5-C42	P2546124	42	92	114	100	3.45
6	MTA6-C42	P2546125	42	92	99	110	4.14

► In case of MT6, it is required to inform machine model number and company name for selection of cutter groove.



**DIN 228-MTB**

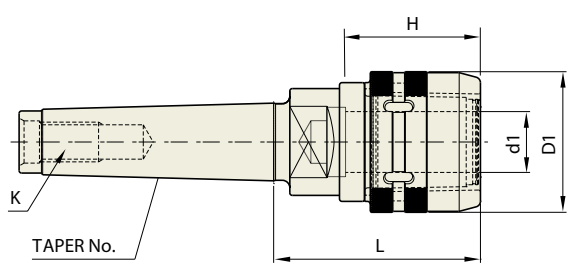

Collet, spanner, refer to page 176

Unit : mm

TAPER No.	MODEL No.	EDP No.	d1	D1	L	H	K	WEIGHT (kg)
3	MTB3-C20	P2546126	20	54	74	65	M12	2.10
4	MTB4-C32	P2546127	32	72	98	80	M16	2.57
5	MTB5-C32	P2546128	32	72	85	100	M20	3.06
	MTB5-C42	P2546129	42	92	114	100	M20	3.45

## POWER MILLING CHUCK



- Rigidity is strengthened through slot made at inside milling chuck, which prevents deformation of milling chuck. Smooth cutting is achieved by maximizing end mill clamping power.
- Enough thickness of clamping part prevents chattering and ensures durability.

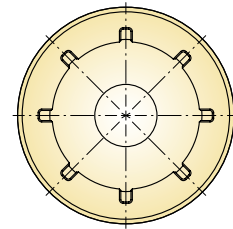

- High precision can be achieved through accurate roundness of clamping part, deburred surface and rigidity (deviation of concentricity : below 2, roughness : below RZ B1.0~1.5)
- Maintaining T.I.R not exceeding 0.01mm at 3D from nose part

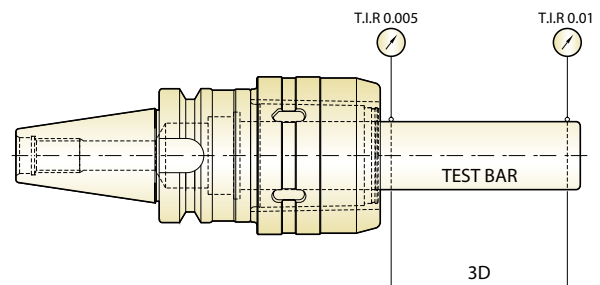

- 160% more of bearings are used in needle roller than other make's chucks, which provides strong clamping power and high durability by dispersing surface pressure even in case strong load is applied.

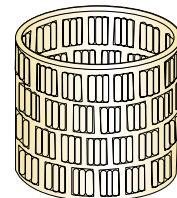

- In order to improve durability, YG-1 milling chuck is passed through following processes.
  - "Normalizing" treatment for unifying material composition and removal internal stress.
  - Ultralow temperature (-90°C) treatment called "Sub-Zero treatment" after carburizing heat treatment for prior removal of any deformation of milling chuck after use for long periods of time.

### High-Speed POWER MILLING CHUCK

- Achieving optimum cutting for High-Speed heavy duty cutting and finishing with strong torque power
- Perfect clamping from 3mm depth of I.D entrance
- Achieving stability when exchanging and setting tools by stable fastening and unfastening torque



### Strong Torque Power

Milling chuck (I.D)	Standard	Tolerance (Taper shank)	Run-out	Clamping torque
C20	AT3	ISO 30 (0~+0.002) ISO 40 (0~+0.003) ISO 50 (0~+0.004)	0.01mm at 3D	980Nm
C25				1,760Nm
C32				3,430Nm
C42				4,900Nm



**TECHNICAL DATA : SHANK STANDARD**

**DIN 228 (MORSE TAPER)  
TANG TYPE (MTA)**

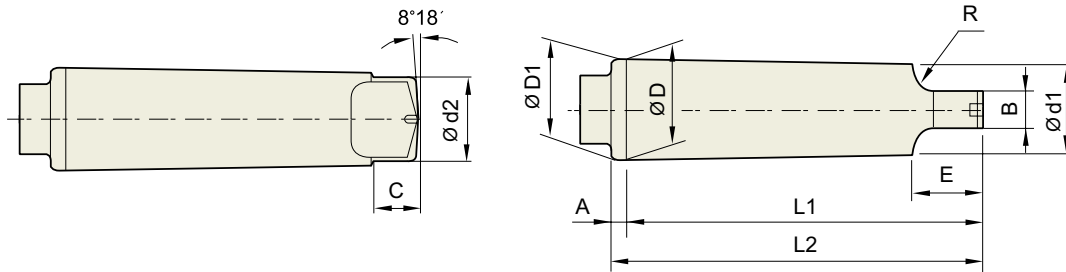

Unit : mm

TAPER No.	TAPER RATIO (Rad)	TAPER ANGLE (α)	ØD	A3	ØD1	Ød1	L1	L2	Ød2	B	C	E	R
MT0	1/19.212	1°29'27"	9.045	3	9.045	6.104	56.5	59.5	6.0	3.9	6.5	10.5	4
MT1	1/20.047	1°25'43"	12.065	3.5	12.065	8.972	62.0	65.5	8.7	5.2	8.5	13.5	5
MT2	1/20.020	1°25'50"	17.780	5	17.780	14.034	75.0	80.0	13.5	6.3	10	16	6
MT3	1/19.922	1°26'16"	23.825	5	23.825	19.107	94.0	99.0	18.5	7.9	13	20	7
MT4	1/19.254	1°29'15"	31.267	6.5	31.267	25.164	117.5	124.0	24.5	11.9	16	24	8
MT5	1/19.002	1°30'26"	44.399	6.5	44.399	36.531	149.5	156.0	35.7	15.9	19	29	10
MT6	1/19.180	1°29'36"	63.348	8	63.348	52.399	210.0	218.0	51.0	19.0	27	40	13
MT7	1/19.231	1°29'22"	83.058	10	83.058	68.186	286.0	296.0	66.8	28.6	35	54	19

**DIN 228 (MORSE TAPER)  
SCREW TYPE (MTB)**

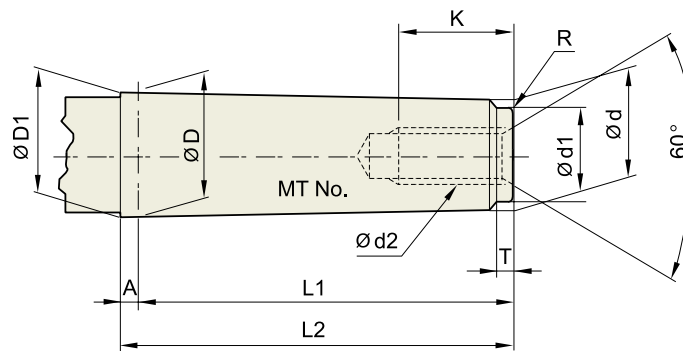

Unit : mm

TAPER No.	TAPER RATIO (Rad)	TAPER ANGLE (α)	ØD	A	ØD1	d	L1	L2	Ød1	d2	K	T	R
MT0	1/19.212	1°29'27"	9.045	3	9.201	6.442	50	53	6.4	-	-	4	0.2
MT1	1/20.047	1°25'43"	12.065	3.5	12.230	9.396	53.5	57	9.4	M6	16	5	0.2
MT2	1/20.020	1°25'50"	17.780	5	18.030	14.583	64	69	14.6	M10	24	5	0.2
MT3	1/19.922	1°26'16"	23.825	5	24.076	19.759	81	86	19.8	M12	28	7	0.6
MT4	1/19.254	1°29'15"	31.267	6.5	31.605	25.943	102.5	109	25.9	M16	32	9	1
MT5	1/19.002	1°30'26"	44.399	6.5	44.741	37.584	129.5	136	37.6	M20	40	9	2.5
MT6	1/19.180	1°29'36"	63.348	8	63.765	53.859	182	190	53.9	M24	50	12	4
MT7	1/19.231	1°29'22"	83.058	10	83.578	70.058	250	260	70.0	M33	80	18.5	5

# MODEL NUMBERING SYSTEM & SURFACE FINISH

## Model Numbering System

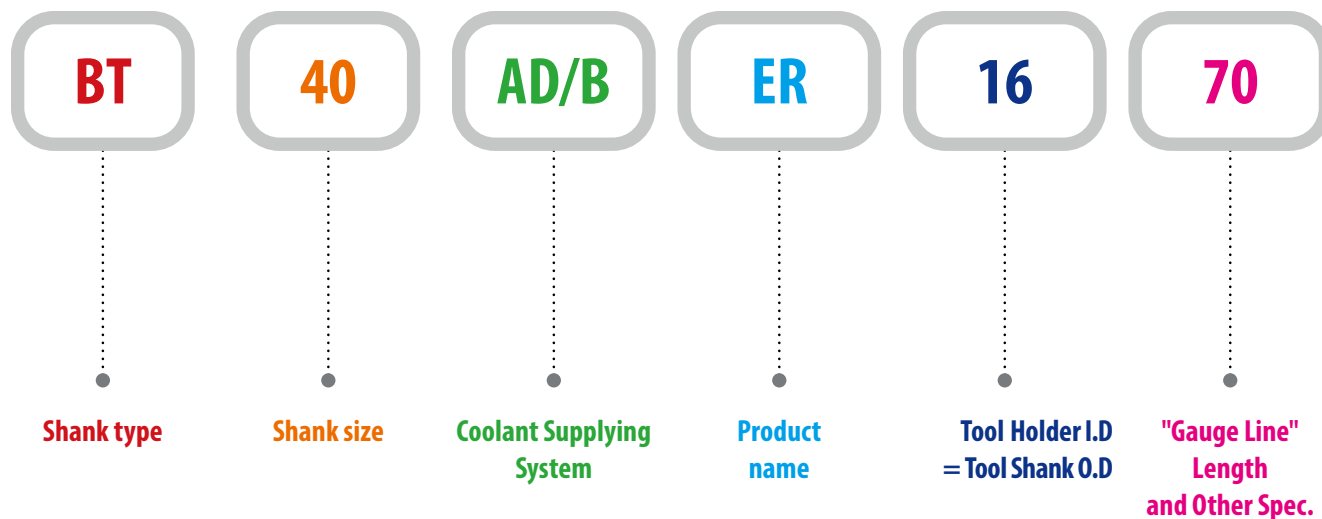

## Surface Finish

