

Code Keys - Milling Cutters

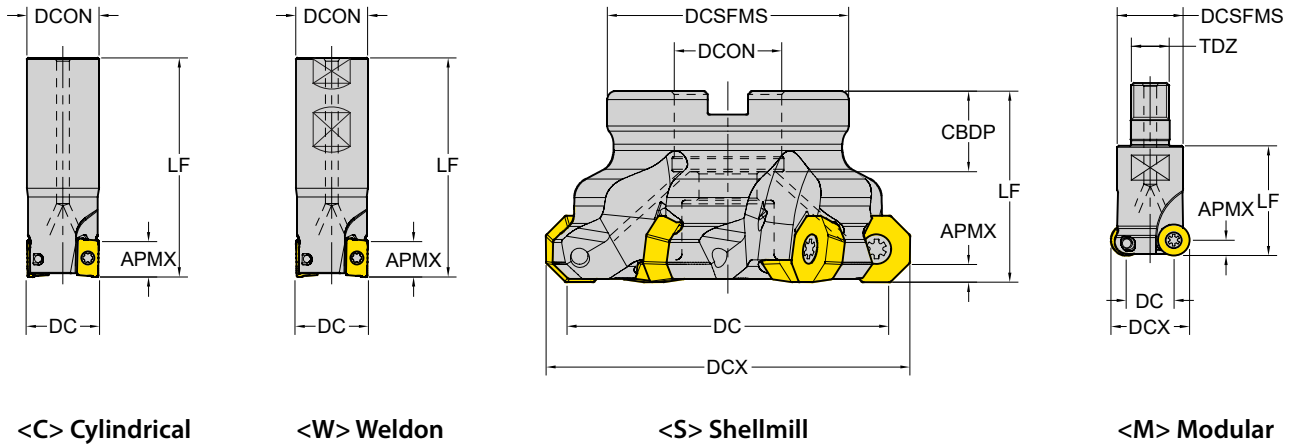

Entering Cutting Angle
(90°)

Cutter Diameter
(Ø16)

Connection Type and Size
C - Cylindrical W - Weldon
S - Shellmill M - Modular
(Cylindrical Ø16)

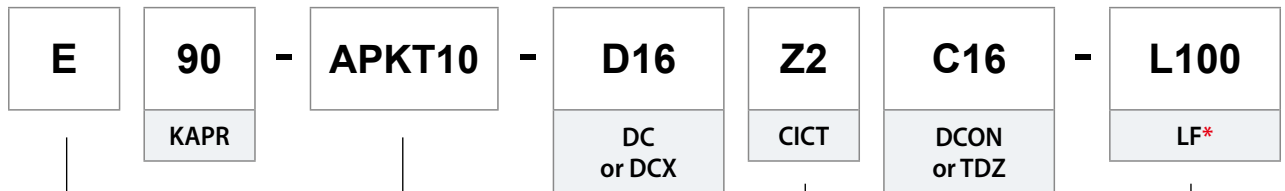

Cutter Type
E - Endmill Type
F - Facemill Type
M - Modular Type

Insert Series
(APKT 10)

Number of Teeth
(Z=2)









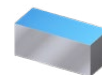

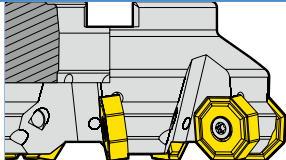
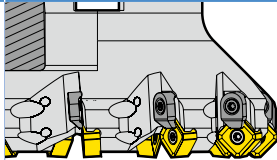
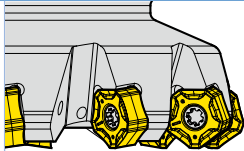

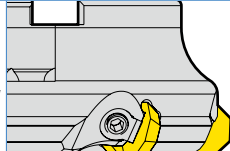
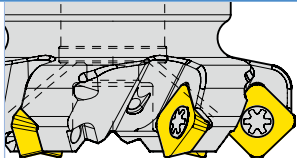
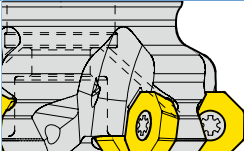
Functional Length
(100mm)

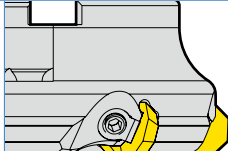
Milling Cutters Overview

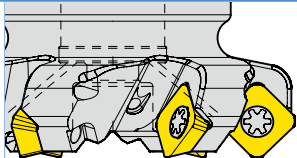
Mounting Bolt : p. 197



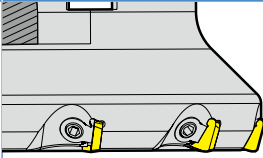



Face Milling

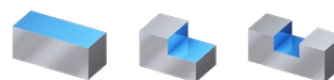

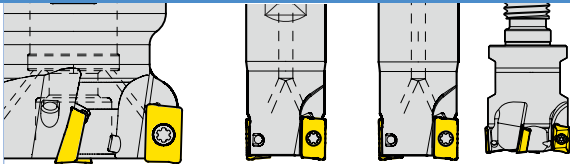
| Negative Octagonal | | Negative Square | |
|--------------------|---|--|--|
| Cutter |   |   | |
| APMX | 5.5 | | 6 |
| DC | Ø63~315 | | Ø50~200 |
| page | 185 | | 192 |
| Negative 10 Corner | | Positive Octagonal | |
| Cutter |   |   |   |
| APMX | 4 | 3.5 | 5 |
| DC | Ø50~125 | Ø63~125 | Ø63~160 |
| page | 186 | 184 | 184 |
| Positive Square | | | ISO |
| Cutter |     | |   |
| APMX | 6 | 6 | 6 |
| DC | Ø40~160 | Ø50~160 | Ø50~160 |
| page | 190 | 190 | 190 |
| | | | 8 |
| | | | Ø50~200 |
| | | | 191 |

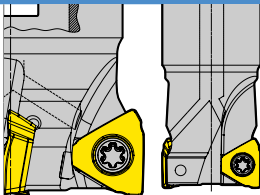
Shoulder Milling

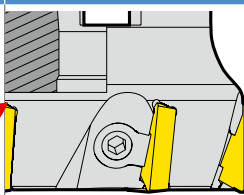

| 2 Corner Positive | | ISO | |
|-------------------|---|--|---|
| Cutter |  |  |  |
| APMX | | 9 | 14 |
| DC | | Ø16~100 | Ø25~200 |
| page | | 178-179 | 180-181 |
| 3 Corner Positive | | ISO | |
| Cutter |    |    | |
| APMX | 7.0 | 11.0 | 12 |
| DC | 20~63 | 32~200 | Ø50~125 |
| page | 194 | 195 | 193 |
| | | | 18 |
| | | | Ø63~315 |
| | | | 193 |

TURNING

PARTING & GROOVING

MILLING

DRILLING

TECHNICAL INFORMATION

 Click/Touch each page number and move to the very page!

Milling Cutters Overview

Mounting Bolt : p. 197

Shoulder Milling

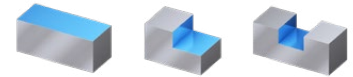

6 Corner Negative

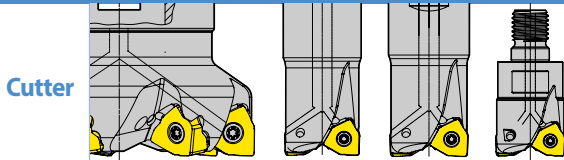

Cutter



WNEX0806

| | |
|------|---------|
| APMX | 7 |
| DC | Ø32~125 |
| page | 196 |

Profiling

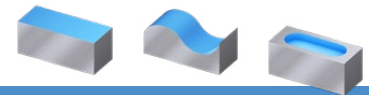

Round Positive

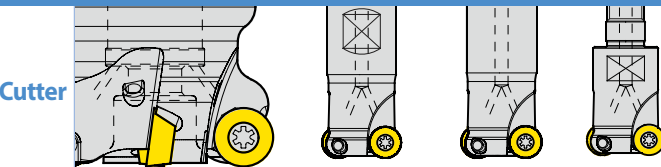

Cutter



RDKT / RDKW

| | | | |
|------|--------|--------|---------|
| | 0802 | 10T3 | 1204 |
| APMX | 4 | 5 | 6 |
| DCX | Ø16~25 | Ø20~63 | Ø25~100 |
| page | 187 | 187 | 188 |

High Feed Milling

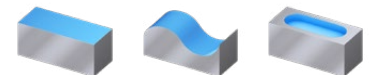

Negative 4 Corner

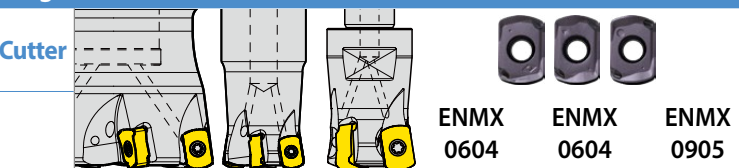

Cutter



| | | |
|-----------|-----------|-----------|
| ENMX 0604 | ENMX 0604 | ENMX 0905 |
| 0.9 | 1 | 1.5 |
| Ø16~18 | Ø20~50 | Ø25~125 |
| 182 | 182 | 183 |

Positive 4 Corner

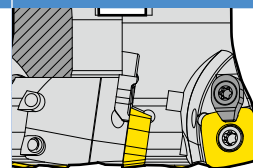

| |
|----------------|
| SDMT/SDMW 1204 |
| 1.8 |
| Ø32~100 |
| 189 |

| | | | | |
|------|--------|--------|---------|---------|
| APMX | 0.9 | 1 | 1.5 | 1.8 |
| DCX | Ø16~18 | Ø20~50 | Ø25~125 | Ø32~100 |
| page | 182 | 182 | 183 | 189 |

Modular Shank

Modular Shank for Modular Head

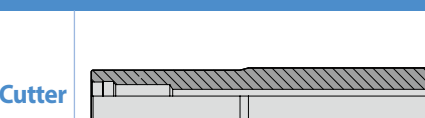

Cutter

M08 ~ M16

| | |
|------|-----|
| page | 197 |
|------|-----|