

HYDRAULIC CHUCK (Radial Tool Length Pre-Setting Type)

DIN 69871-SK

HYDRAULIK SPANNFUTTER (RADIALE WERKZEUGLÄGEN VOREINSTELLUNG)
 MANDRIN HYDRAULIQUE (BANC DE PRÉ-RÉGLAGE RADIAL)
 MANDRINI IDRAULICI (UTENSILI RADIALI PER AZZERAMENTO)
 PORTAHERRAMIENTAS HIDRAULICO (AJUSTE DE LONGITUD TIPO PRE-SETTING)

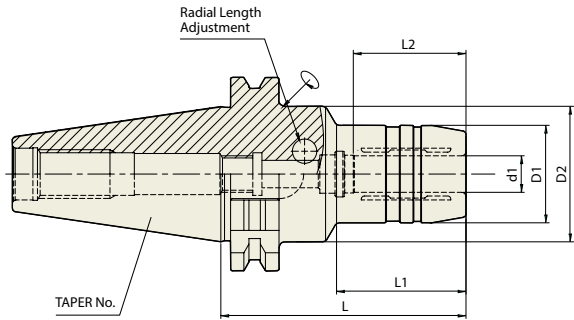

Collet
Refer to page 43-46

Unit : mm

TAPER No.	MODEL No.	EDP No.	d1	D1	D2	L	L1	L2	WEIGHT (kg)
30	SK30AD/B-HCR12-85	P2770001	12	32	44.5	85	40	37	0.90
	SK30AD/B-HCR20-85	P2770003	20	44	-	85	-	42	1.00
40	SK40AD/B-HCR12-80.5	P2554018	12	32	49.5	80.5	31.5	37	1.50
	SK40AD/B-HCR20-80.5	P2554019	20	42	49.5	80.5	34	42	1.60
	SK40AD/B-HCR32-110	P2770004	32	63	80	110	50	55	2.20
50	SK50AD/B-HCR12-80.5	P2770005	12	32	49.5	80.5	35	37	3.90
	SK50AD/B-HCR20-80.5	P2770006	20	42	44.5	80.5	44	42	4.00
	SK50AD/B-HCR32-100	P2770002	32	60	-	100	-	55	4.70

► CAT(ANSI B5.50) taper and Inch type products are available.

HYDRAULIC CHUCK

- High precision T.I.R:**
 $\leq 0.003\text{mm}$ (Without Reduction Sleeve)

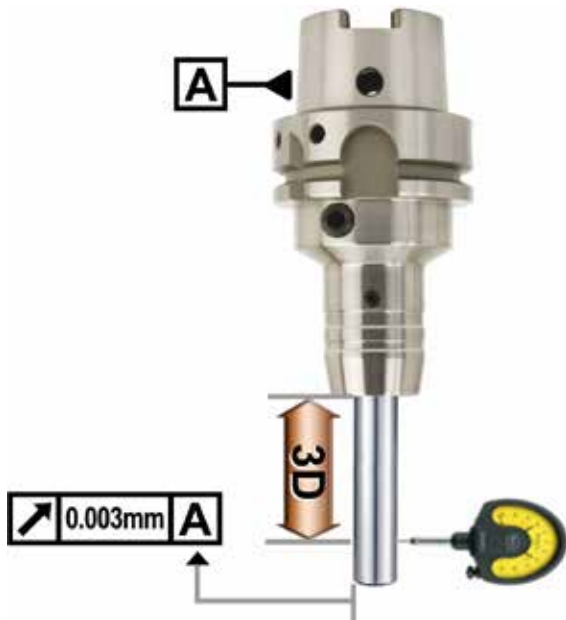

- Less than 0.003mm T.I.R =>
 Suitable for High-Speed precision machining

- Flexible use of cutting tools by using of reduction sleeves**

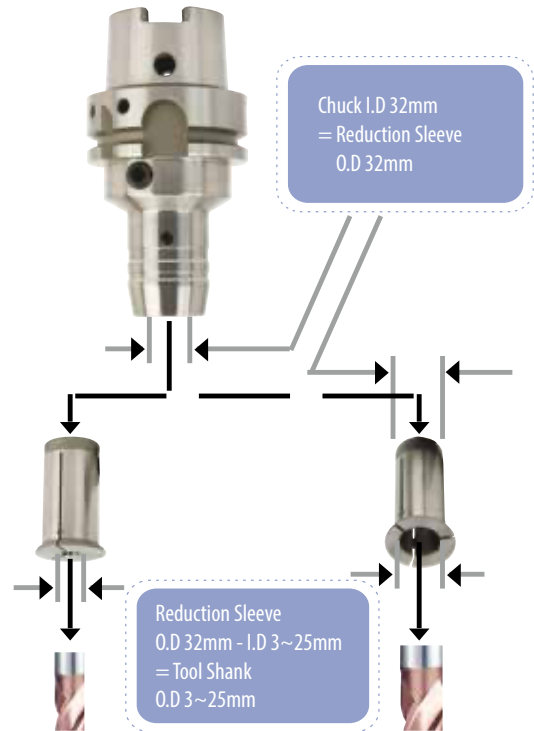

- Easy Tool Change**

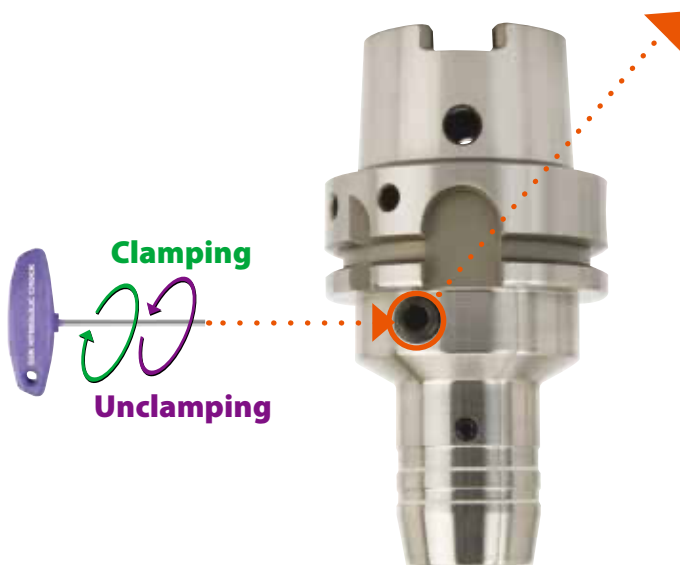

- Easy clamping and unclamping by use of T wrench =>
 Reducing tool change time

CLAMPING SCREW

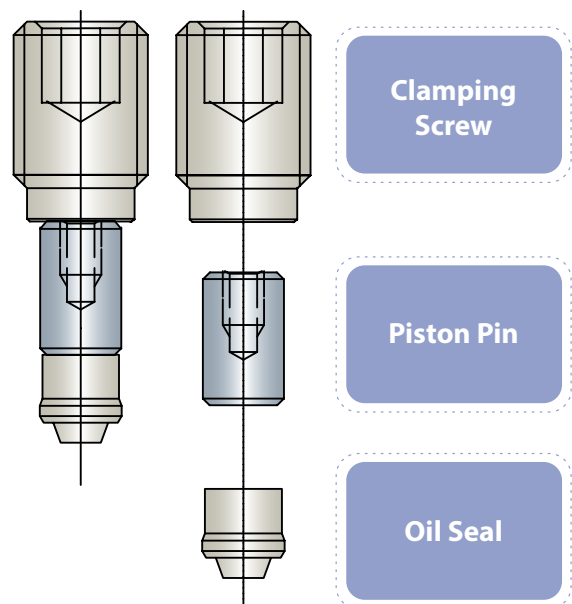

Strong Torque Power

Hydraulic Chuck I.D(mm)	Tool Shank O.D(mm)	Applicable RPM	Minimum Clamping Depth (mm)		Min. Torque Power (Nm)	
			Slim	Power E Hydro	Slim	Power E Hydro
6	6	40,000	27		16	
8	8	40,000	27		23	
10	10	40,000	32		45	
12	12	40,000	27	41	90	110
14	14	40,000	37		110	
16	16	40,000	42		185	
18	18	40,000	42		240	
20	20	40,000	42	48	330	520
25	25	25,000	48		400	
32	32	25,000	55	57	650	900

- Tool Holder I.D Tolerance : H6
- Operating Temperature : 20~25°C
- Maximum pressure of coolant oil : 80bar



Test of Torque Power and Hydraulic Oil Leakage

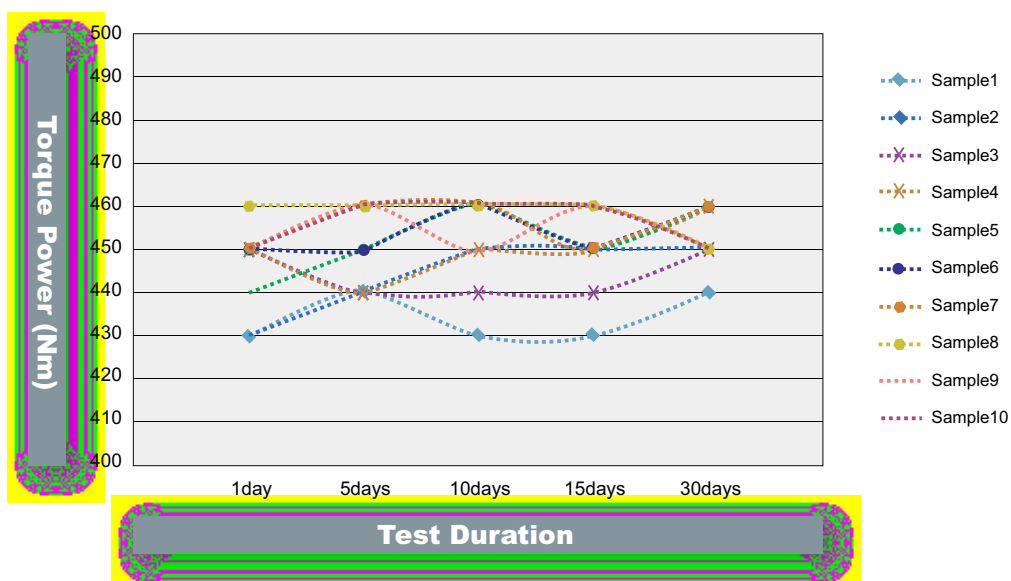

- Test Model : BT40AD/B-HC20-90
- No oil leakage for long period ⇒ Maintaining stable torque power

HYDRAULIC CHUCK

Radial tool length pre-setting type

- Easy to adjust pre-setting length of cutting tool
(Saving time to pre-set cutting tool to one fifth compared with conventional Hydraulic Chuck)
- Precise adjustment of cutting tool length
- Designed to separate tool length adjustment screw from clamping screw

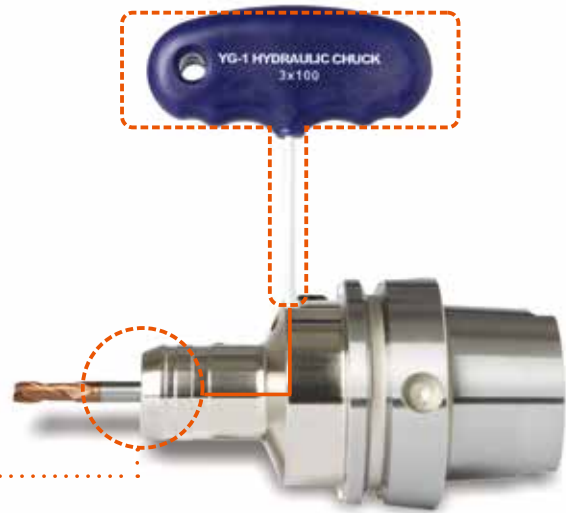

Adjustable range of cutting tool length : 0~10mm

APPLICATION		
<p>Milling</p>	<p>High-Speed Cutting</p>	<p>Fine Drilling</p>
<p>Reaming</p>	<p>Tapping & Thread Milling</p>	<p>Chamfering</p>

TECHNICAL DATA : SHANK STANDARD

DIN 69871-SK

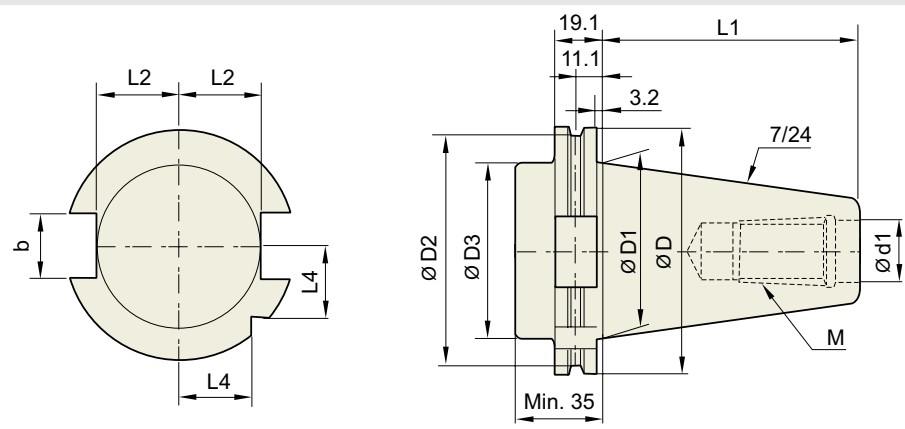

Unit : mm

TAPER No.	ØD	ØD1	ØD2	ØD3	Ød1	L1	L2	L3	L4	b	M
SK30	50	31.75	44.3	45	13	47.8	16.4	19	15	16.1	M12×1.75
SK40	63.55	44.45	56.25	50	17	68.4	22.8	25	18.5	16.1	M16×2.0
SK50	97.5	69.85	91.25	80	25	101.75	35.5	37.7	30	25.7	M24×3.0

JIS B6339/ MAS 403-BT

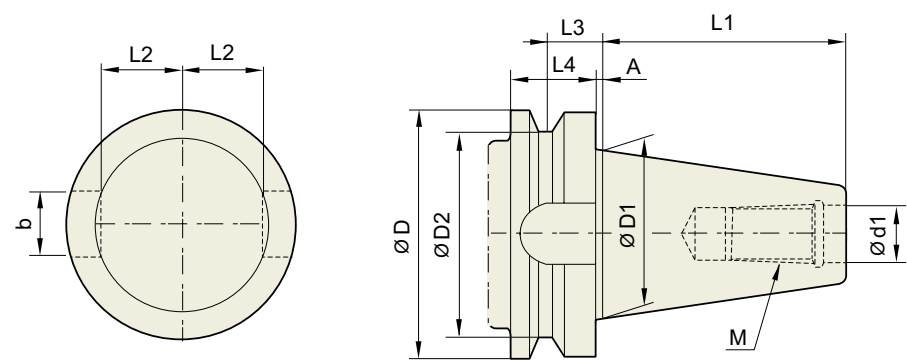

Unit : mm

TAPER No.	ØD	ØD1	ØD2	Ød13.	L1	L2	L3	L4	A	b	M
BT30	46	31.75	38	12.5	48.4	16.3	13.6	20	2	16.1	M12×1.75
BT40	63	44.45	53	17	65.4	22.6	16.6	25	2	16.1	M16×2
BT50	100	69.85	85	25	101.8	35.4	23.2	35	3	25.7	M24×3
BT60	155	107.95	135	31	161.8	60.1	28.2	45	3	25.7	M30×3.5

MODEL NUMBERING SYSTEM & SURFACE FINISH

Model Numbering System

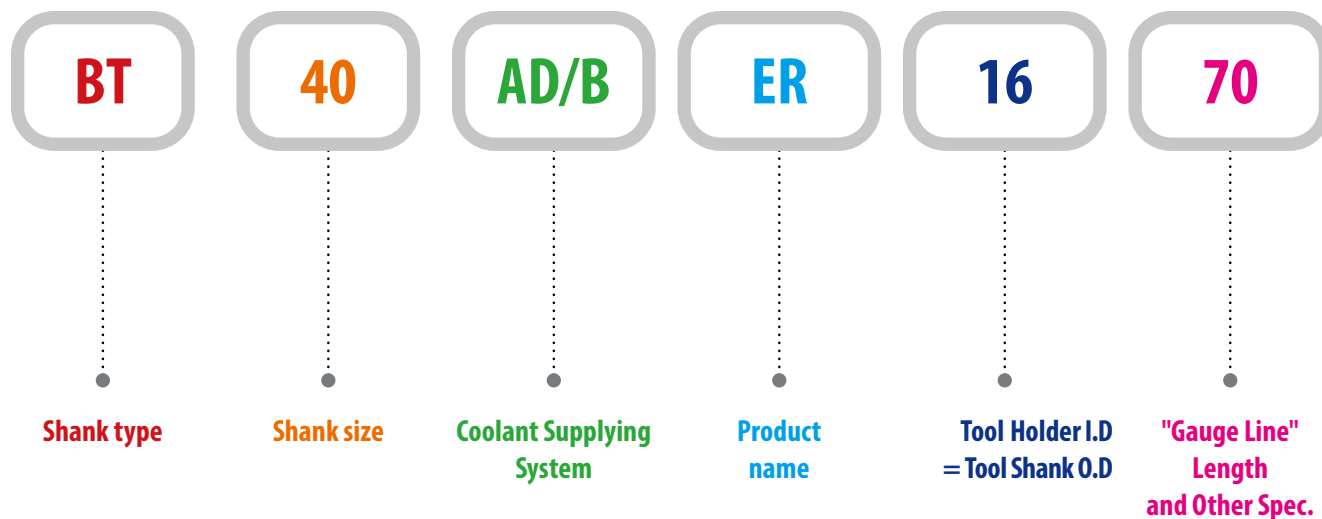

Surface Finish

