

**HYDRAULIC CHUCK (Power E Hydro)**

**DIN 69871-SK**

HYDRAULIK SPANNFUTTER (POWER E HYDRO)  
 MANDRIN HYDRAULIQUE (POWER E HYDRO)  
 MANDRINI IDRAULICI (POWER E HYDRO)  
 PORTAHERRAMIENTAS HIDRAULICO (POWER E HYDRO)

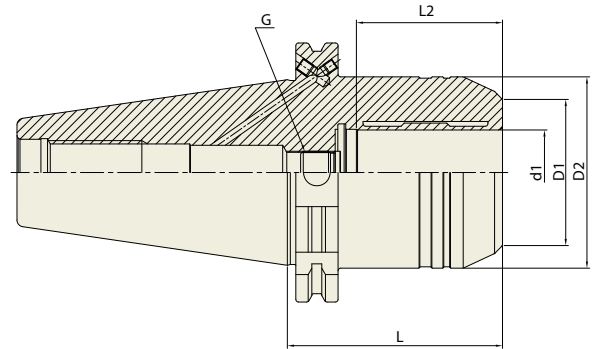

Collet  
Refer to page 43-46

Unit : mm

TAPER No.	MODEL No.	EDP No.	d1	D1	D2	L	L2	G	WEIGHT (kg)
40	SK40AD/B-HC12P-50	P2776651P	12	32	42	50	41	M8x1.0	1.00
	SK40AD/B-HC20P-64.5	P2534001P	20	38	49.5	64.5	48	M8x1.0	1.20
50	SK50AD/B-HC20P-64.5	P2756010P	20	38	49.5	64.5	48	M8x1.0	2.80
	SK50AD/B-HC32P-81	P2534002P	32	58.5	72	81	57	M8x1.0	3.90

► CAT(ANSI B5.50) taper and Inch type products are available.

## HYDRAULIC CHUCK

- High precision T.I.R:**  
 $\leq 0.003\text{mm}$  (Without Reduction Sleeve)

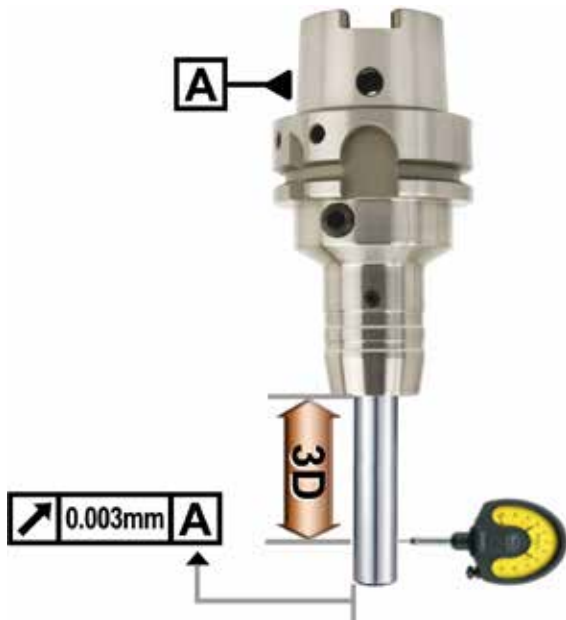

- Less than 0.003mm T.I.R =>  
 Suitable for High-Speed precision machining

- Flexible use of cutting tools by using of reduction sleeves**

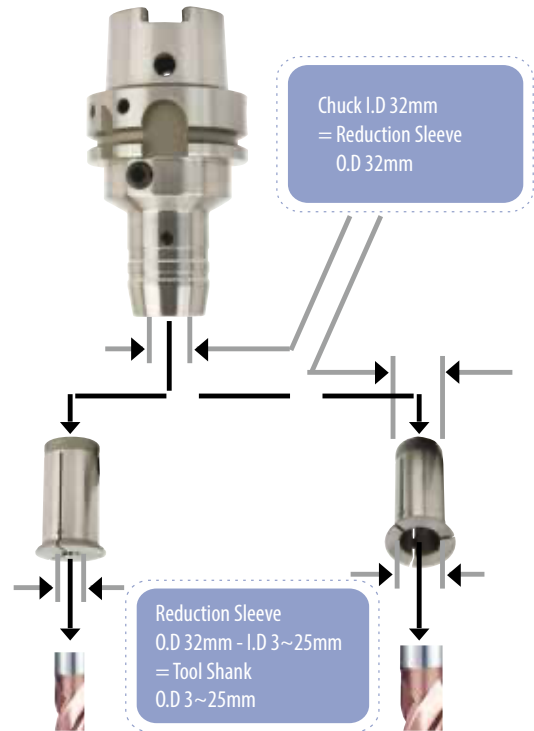

- Easy Tool Change**

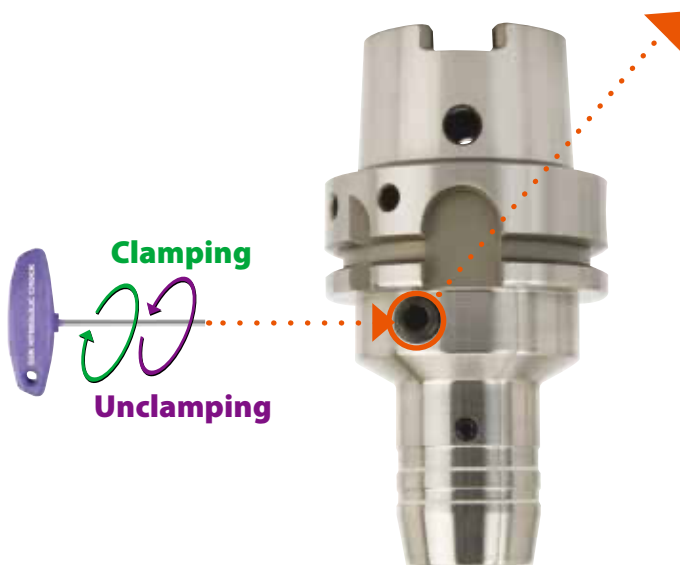

### CLAMPING SCREW

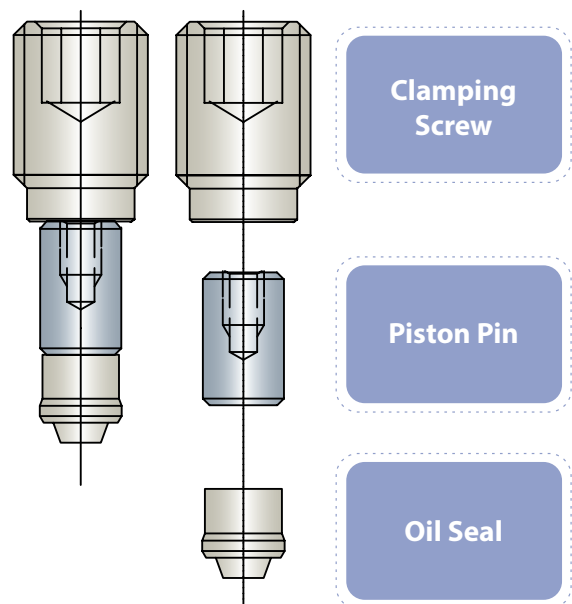

- Easy clamping and unclamping by use of T wrench =>  
 Reducing tool change time

### Strong Torque Power

Hydraulic Chuck I.D(mm)	Tool Shank O.D(mm)	Applicable RPM	Minimum Clamping Depth (mm)		Min. Torque Power (Nm)	
			Slim	Power E Hydro	Slim	Power E Hydro
6	6	40,000	27		16	
8	8	40,000	27		23	
10	10	40,000	32		45	
12	12	40,000	27	41	90	110
14	14	40,000	37		110	
16	16	40,000	42		185	
18	18	40,000	42		240	
20	20	40,000	42	48	330	520
25	25	25,000	48		400	
32	32	25,000	55	57	650	900

- Tool Holder I.D Tolerance : H6
- Operating Temperature : 20~25°C
- Maximum pressure of coolant oil : 80bar



### Test of Torque Power and Hydraulic Oil Leakage

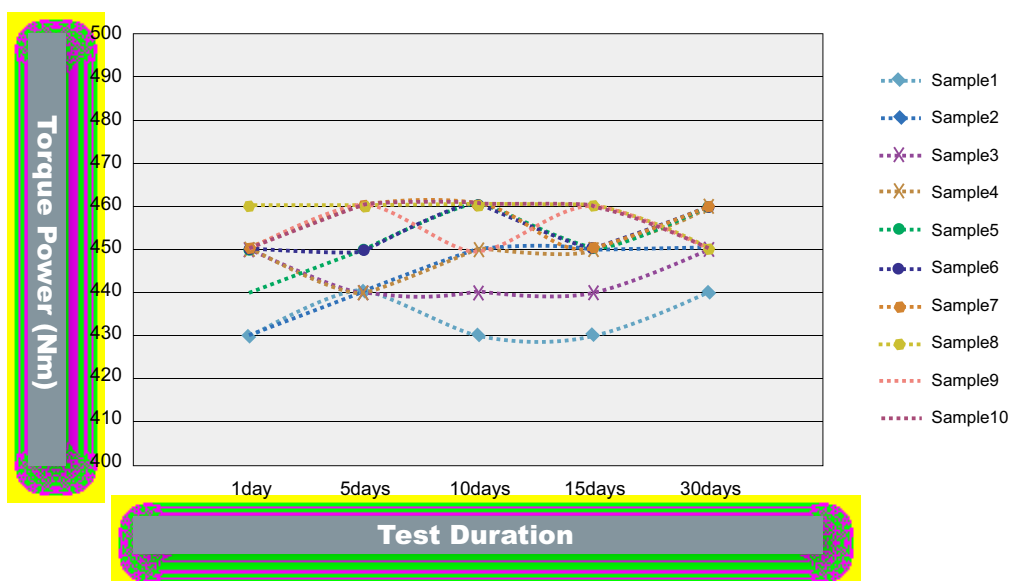

- Test Model : BT40AD/B-HC20-90
- No oil leakage for long period ⇒ Maintaining stable torque power

## HYDRAULIC CHUCK

### Radial tool length pre-setting type

- Easy to adjust pre-setting length of cutting tool  
(Saving time to pre-set cutting tool to one fifth compared with conventional Hydraulic Chuck)
- Precise adjustment of cutting tool length
- Designed to separate tool length adjustment screw from clamping screw



Adjustable range of cutting tool length : 0~10mm

APPLICATION		
<p><b>Milling</b></p>	<p><b>High-Speed Cutting</b></p>	<p><b>Fine Drilling</b></p>
<p><b>Reaming</b></p>	<p><b>Tapping &amp; Thread Milling</b></p>	<p><b>Chamfering</b></p>

**TECHNICAL DATA : SHANK STANDARD**

**DIN 69871-SK**

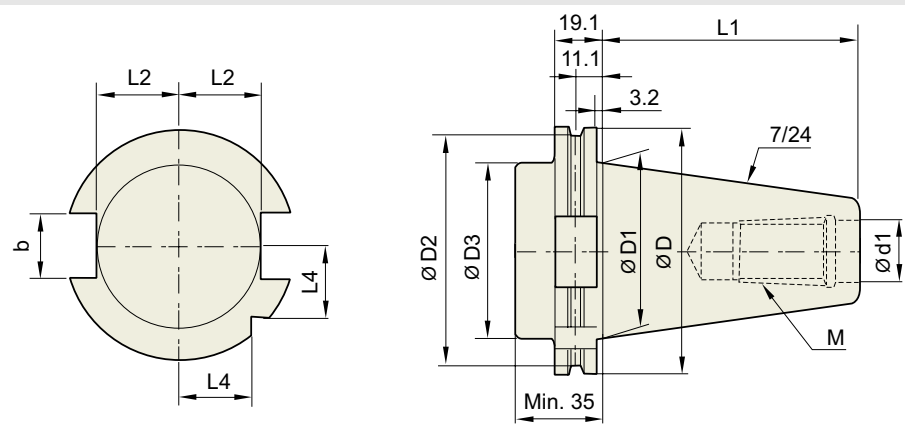

Unit : mm

TAPER No.	ØD	ØD1	ØD2	ØD3	Ød1	L1	L2	L3	L4	b	M
SK30	50	31.75	44.3	45	13	47.8	16.4	19	15	16.1	M12×1.75
SK40	63.55	44.45	56.25	50	17	68.4	22.8	25	18.5	16.1	M16×2.0
SK50	97.5	69.85	91.25	80	25	101.75	35.5	37.7	30	25.7	M24×3.0

**JIS B6339/ MAS 403-BT**

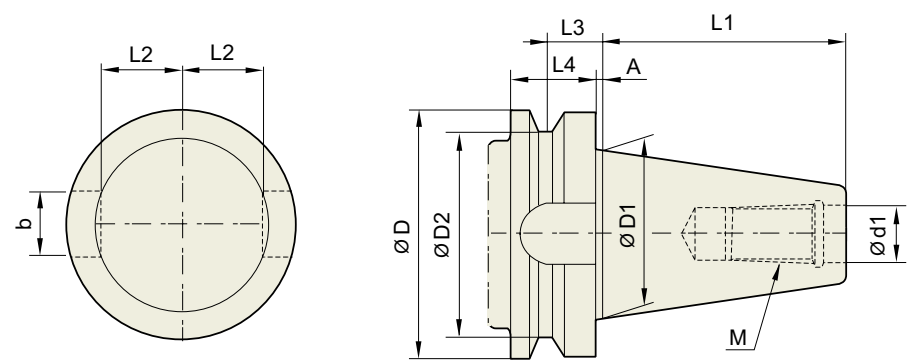

Unit : mm

TAPER No.	ØD	ØD1	ØD2	Ød13.	L1	L2	L3	L4	A	b	M
BT30	46	31.75	38	12.5	48.4	16.3	13.6	20	2	16.1	M12×1.75
BT40	63	44.45	53	17	65.4	22.6	16.6	25	2	16.1	M16×2
BT50	100	69.85	85	25	101.8	35.4	23.2	35	3	25.7	M24×3
BT60	155	107.95	135	31	161.8	60.1	28.2	45	3	25.7	M30×3.5

# MODEL NUMBERING SYSTEM & SURFACE FINISH

## Model Numbering System

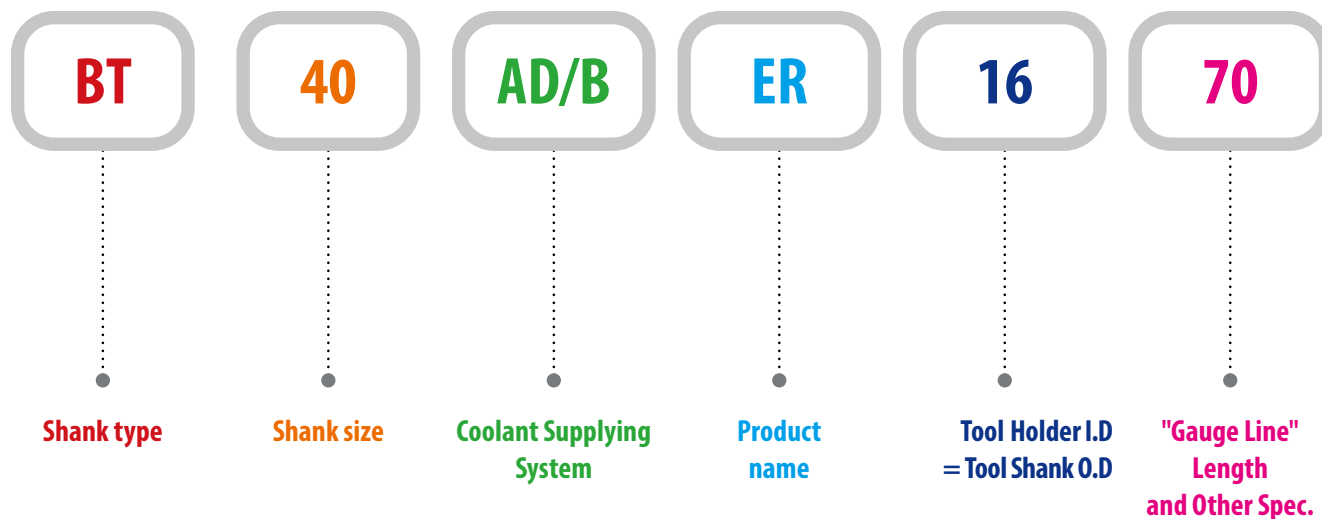

## Surface Finish

