



ER COLLET CHUCK

ER

ER COLLET CHUCK

DIN 69871-SK

FRÄSERSPANNFUTTER - ER
MANDRIN À PINCES - ER
MANDRINO PORTA PINZE - ER
PORTAPINZAS - ER

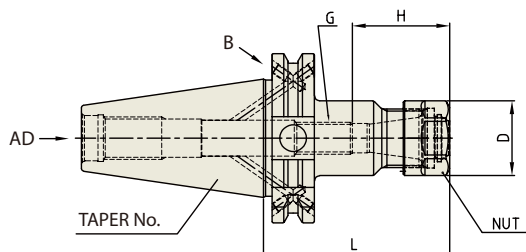

ER Collet
Refer to page 103-109



ER nut, Sealing disk and Spanner
Refer to page 110-115

Unit : mm

TAPER No.	MODEL No.	EDP No.	CLAMPING RANGE	L	D	G	H	NUT / COLLET	WEIGHT (kg)
40	SK40AD/B-ER11-70	P2774812	0.5 - 7.0	70	19	M6	45	ER11	0.90
	SK40AD/B-ER11-100	P2774826	0.5 - 7.0	100	19	M6	45	ER11	0.95
	SK40AD/B-ER16-70	P2774801	0.5 - 10.0	70	28	M12	36	ER16	0.44
	SK40AD/B-ER16-100	P2774804	0.5 - 10.0	100	28	M12	36	ER16	0.56
	SK40AD/B-ER16-130	P2774827	0.5 - 10.0	130	28	M12	36	ER16	0.69
	SK40AD/B-ER16-160	P2774828	0.5 - 10.0	160	28	M12	36	ER16	0.81
	SK40AD/B-ER20-70	P2774813	0.5 - 13.0	70	34	M12	44.5	ER20	0.47
	SK40AD/B-ER20-100	P2774820	0.5 - 13.0	100	34	M12	44.5	ER20	0.64
	SK40AD/B-ER20-130	P2774829	0.5 - 13.0	130	34	M12	44.5	ER20	0.80
	SK40AD/B-ER20-160	P2774830	0.5 - 13.0	160	34	M12	44.5	ER20	1.00
	SK40AD/B-ER25-70	P2774802	1.0 - 16.0	70	42	M12	52	ER25	0.56
	SK40AD/B-ER25-100	P2774805	1.0 - 16.0	100	42	M12	52	ER25	0.84
	SK40AD/B-ER25-130	P2774831	1.0 - 16.0	130	42	M12	52	ER25	1.14
	SK40AD/B-ER25-160	P2774832	1.0 - 16.0	160	42	M12	52	ER25	1.44
	SK40AD/B-ER32-70	P2774803	1.0 - 20.0	70	50	M12	60	ER32	0.51
	SK40AD/B-ER32-100	P2774806	1.0 - 20.0	100	50	M12	60	ER32	0.88
	SK40AD/B-ER32-130	P2774833	1.0 - 20.0	130	50	M12	60	ER32	1.21
	SK40AD/B-ER32-160	P2774834	1.0 - 20.0	160	50	M12	60	ER32	1.54
	SK40AD/B-ER40-80	P2774814	2.0 - 30.0	80	63	M12	53	ER40	0.65
	SK40AD/B-ER40-100	P2774835	2.0 - 30.0	100	63	M12	75	ER40	0.90
SK40AD/B-ER40-130	P2774836	2.0 - 30.0	130	63	M12	75	ER40	1.34	
SK40AD/B-ER40-160	P2774837	2.0 - 30.0	160	63	M12	75	ER40	1.77	
50	SK50AD/B-ER16-70	P2774815	0.5 - 10.0	70	28	M12	36	ER16	2.71
	SK50AD/B-ER16-100	P2774821	0.5 - 10.0	100	28	M12	45	ER16	2.82
	SK50AD/B-ER16-130	P2774838	0.5 - 10.0	130	28	M12	36	ER16	2.92
	SK50AD/B-ER16-160	P2774839	0.5 - 10.0	160	28	M12	36	ER16	3.01
	SK50AD/B-ER20-70	P2774816	0.5 - 13.0	70	34	M12	44.5	ER20	2.78
	SK50AD/B-ER20-100	P2774822	0.5 - 13.0	100	34	M12	50	ER20	2.88
	SK50AD/B-ER20-130	P2774840	0.5 - 13.0	130	34	M12	50	ER20	3.02
	SK50AD/B-ER20-160	P2774841	0.5 - 13.0	160	34	M12	50	ER20	3.16
	SK50AD/B-ER25-70	P2774817	1.0 - 16.0	70	42	M12	65	ER25	2.75
	SK50AD/B-ER25-100	P2774823	1.0 - 16.0	100	42	M12	52	ER25	3.06
	SK50AD/B-ER25-130	P2774842	1.0 - 16.0	130	42	M12	42	ER25	3.32
	SK50AD/B-ER25-160	P2774843	1.0 - 16.0	160	42	M12	42	ER25	3.57
	SK50AD/B-ER32-70	P2774818	1.0 - 20.0	70	50	M12	60	ER32	2.84
	SK50AD/B-ER32-100	P2774824	1.0 - 20.0	100	50	M12	60	ER32	3.29
	SK50AD/B-ER32-130	P2774844	1.0 - 20.0	130	50	M12	73	ER32	3.67
	SK50AD/B-ER32-160	P2774845	1.0 - 20.0	160	50	M12	73	ER32	4.06
	SK50AD/B-ER40-80	P2774819	2.0 - 30.0	80	63	M12	69	ER40	3.10
	SK50AD/B-ER40-100	P2774825	2.0 - 30.0	100	63	M12	75	ER40	3.56
	SK50AD/B-ER40-130	P2774846	2.0 - 30.0	130	63	M12	75	ER40	4.22
	SK50AD/B-ER40-160	P2774847	2.0 - 30.0	160	63	M12	75	ER40	4.88

► CAT(ANSI B5.50) taper and Inch type products are available.

ER COLLET CHUCK



FEATURE

- Powerful chucking, high precision and easy operation
- Precise machining is stably maintained without chattering in High-Speed rotation.
- Due to nut designed with small bore, interference with work piece can be minimized and it enables speedy operation.
- Various nuts can be selected and used according to usage.
- Unlike single taper, double taper has long chucking part providing excellent torque power.

HIGH PRECISION

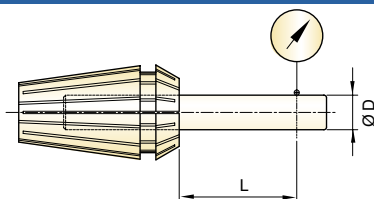

- By using high precision collet, excellent T.I.R can be achievable.
- With fine cutting of 16 sections, it has excellent contractile force, which makes higher precision can be achieved.

D	L	Max.T.I.R(STD.)
Ø1 ~ Ø1.6	6	0.015
Ø1.6 ~ Ø3	10	0.015
Ø3 ~ Ø6	16	0.015
Ø6 ~ Ø10	25	0.015
Ø10 ~ Ø18	40	0.020
Ø18 ~ Ø26	50	0.020
Ø26 ~ Ø34	60	0.020

STRONG TORQUE POWER

- Longer clamping part of double taper collet provides stronger torque power.
- Stronger torque power can be achieved if ball bearing nut is used.

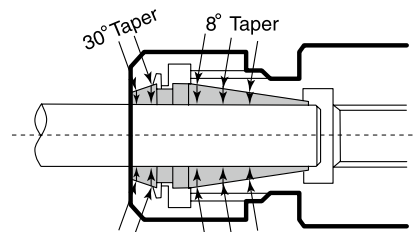

EASY ASSEMBLING AND DISASSEMBLING

- For assembling or disassembling of collet, first gently insert groove part of collet into eccentric portion inside nut, and fasten it to same direction as screw or loosen it reversely.

- Notice :
In case of Ø12.2mm tool, don't use Ø12~11mm collet.
But use collet with Ø12.5~11.5mm.
(In case of general cutting process, Ø13~12mm collet is usable)

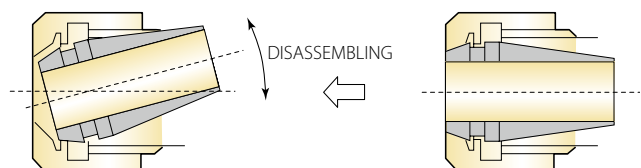

TECHNICAL DATA : SHANK STANDARD

DIN 69871-SK

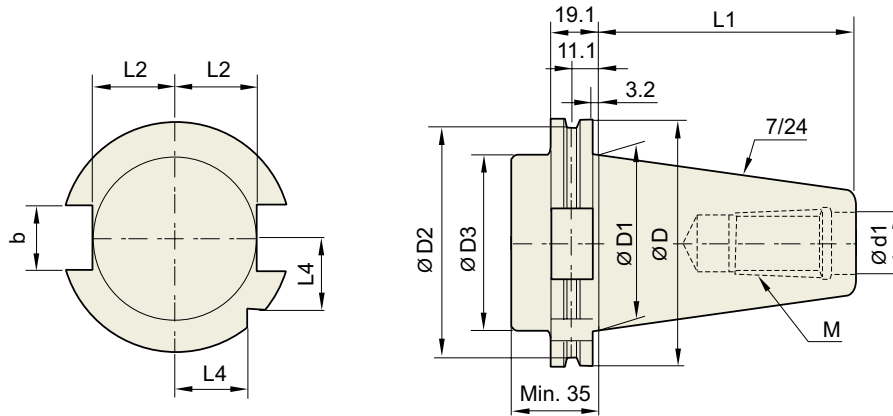

Unit : mm

TAPER No.	ØD	ØD1	ØD2	ØD3	Ød1	L1	L2	L3	L4	b	M
SK30	50	31.75	44.3	45	13	47.8	16.4	19	15	16.1	M12×1.75
SK40	63.55	44.45	56.25	50	17	68.4	22.8	25	18.5	16.1	M16×2.0
SK50	97.5	69.85	91.25	80	25	101.75	35.5	37.7	30	25.7	M24×3.0

JIS B6339/
MAS 403-BT

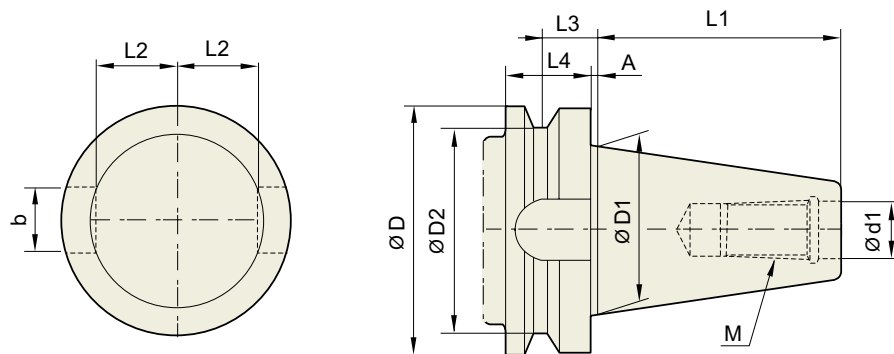

Unit : mm

TAPER No.	ØD	ØD1	ØD2	Ød13.	L1	L2	L3	L4	A	b	M
BT30	46	31.75	38	12.5	48.4	16.3	13.6	20	2	16.1	M12×1.75
BT40	63	44.45	53	17	65.4	22.6	16.6	25	2	16.1	M16×2
BT50	100	69.85	85	25	101.8	35.4	23.2	35	3	25.7	M24×3
BT60	155	107.95	135	31	161.8	60.1	28.2	45	3	25.7	M30×3.5

MODEL NUMBERING SYSTEM & SURFACE FINISH

Model Numbering System

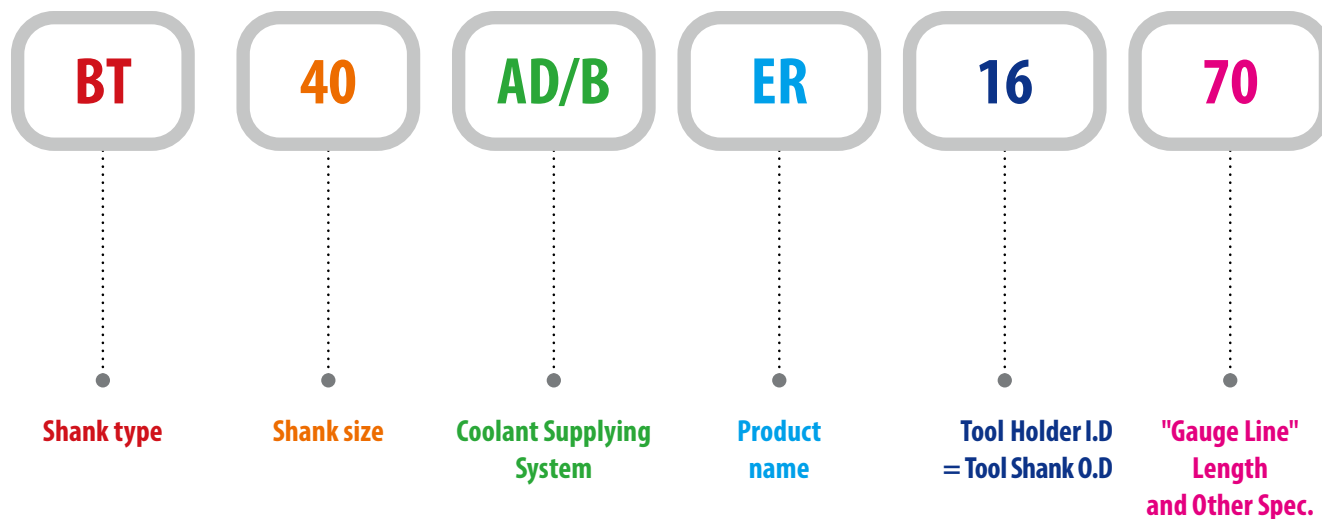

Surface Finish

