

YIG ER COLLET CHUCK

ER

ER COLLET CHUCK

FRÄSERSPANNFUTTER - ER
MANDRIN À PINCES - ER
MANDRINO PORTA PINZE - ER
PORTAPINZAS - ER

JIS B6339/
MAS 403-BT

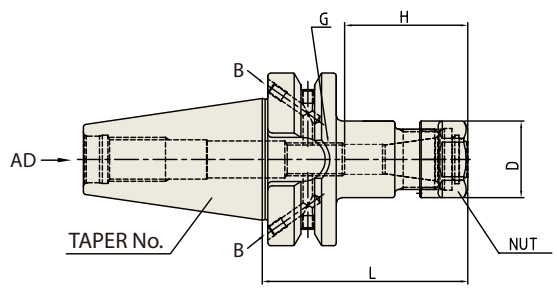

ER Collet Refer to page 103-109
ER nut, Sealing disk and Spanner Refer to page 110-115

TAPER No.	MODEL No.	EDP No.	CLAMPING RANGE	L	D	G	H	NUT / COLLET	WEIGHT (kg)
30	BT30-ER11-70	P2776501A	0.5 - 7.0	70	19	M6	45	ER11	0.50
	BT30-ER11-100	P2776502A	0.5 - 7.0	100	19	M6	45	ER11	0.50
	BT30-ER16-70	P2776503A	0.5 - 10.0	70	28	M12	45	ER16	1.00
	BT30-ER16-100	P2776506A	0.5 - 10.0	100	28	M12	45	ER16	1.10
	BT30-ER20-80	P2776507A	0.5 - 13.0	80	34	M12	50	ER20	1.20
	BT30-ER20-100	P2776508A	0.5 - 13.0	100	34	M12	50	ER20	1.30
	BT30-ER25-70	P2776509A	1.0 - 16.0	70	42	M12	65	ER25	1.20
	BT30-ER25-100	P2776510A	1.0 - 16.0	100	42	M12	65	ER25	1.30
	BT30-ER32-60	P2776511A	1.0 - 20.0	60	50	M12	65	ER32	1.40
	BT30-ER32-90	P2776512A	1.0 - 20.0	90	50	M12	65	ER32	1.90
40	BT40AD/B-ER11-75	P2776513	0.5 - 7.0	75	19	M6	45	ER11	1.00
	BT40AD/B-ER11-100	P2776514	0.5 - 7.0	100	19	M6	45	ER11	1.10
	BT40AD/B-ER16-75	P2776504	0.5 - 10.0	75	28	M12	45	ER16	1.10
	BT40AD/B-ER16-100	P2553021	0.5 - 10.0	100	28	M12	45	ER16	1.20
	BT40AD/B-ER16-120	P2776515	0.5 - 10.0	120	28	M12	45	ER16	1.40
	BT40AD/B-ER20-75	P2776516	0.5 - 13.0	75	34	M12	50	ER20	1.40
	BT40AD/B-ER20-100	P2553017	0.5 - 13.0	100	34	M12	50	ER20	1.80
	BT40AD/B-ER20-135	P2776517	0.5 - 13.0	135	34	M12	50	ER20	2.20
	BT40AD/B-ER25-75	P2600012	1.0 - 16.0	75	42	M12	65	ER25	1.40
	BT40AD/B-ER25-100	P2553018	1.0 - 16.0	100	42	M12	65	ER25	1.80
	BT40AD/B-ER25-135	P2776518	1.0 - 16.0	135	42	M12	65	ER25	2.20
	BT40AD/B-ER25-150	P2776519	1.0 - 16.0	150	42	M12	65	ER25	2.40
	BT40AD/B-ER32-60	P2553501	1.0 - 20.0	60	50	M12	65	ER32	1.80
	BT40AD/B-ER32-100	P2776505	1.0 - 20.0	100	50	M12	65	ER32	2.20

▶ CAT(ANSI B5.50) taper and Inch type products are available.

▶ NEXT PAGE

ER COLLET CHUCK



FEATURE

- Powerful chucking, high precision and easy operation
- Precise machining is stably maintained without chattering in High-Speed rotation.
- Due to nut designed with small bore, interference with work piece can be minimized and it enables speedy operation.
- Various nuts can be selected and used according to usage.
- Unlike single taper, double taper has long chucking part providing excellent torque power.

HIGH PRECISION

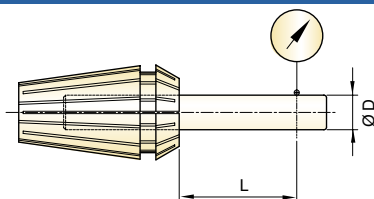

- By using high precision collet, excellent T.I.R can be achievable.
- With fine cutting of 16 sections, it has excellent contractile force, which makes higher precision can be achieved.

D	L	Max.T.I.R(STD.)
Ø1 ~ Ø1.6	6	0.015
Ø1.6 ~ Ø3	10	0.015
Ø3 ~ Ø6	16	0.015
Ø6 ~ Ø10	25	0.015
Ø10 ~ Ø18	40	0.020
Ø18 ~ Ø26	50	0.020
Ø26 ~ Ø34	60	0.020

STRONG TORQUE POWER

- Longer clamping part of double taper collet provides stronger torque power.
- Stronger torque power can be achieved if ball bearing nut is used.

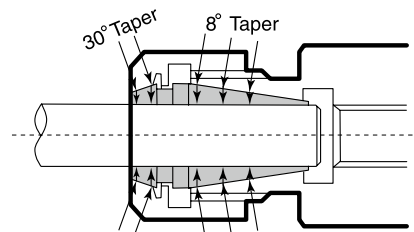

EASY ASSEMBLING AND DISASSEMBLING

- For assembling or disassembling of collet, first gently insert groove part of collet into eccentric portion inside nut, and fasten it to same direction as screw or loosen it reversely.

- Notice :
In case of Ø12.2mm tool, don't use Ø12~11mm collet.
But use collet with Ø12.5~11.5mm.
(In case of general cutting process, Ø13~12mm collet is usable)

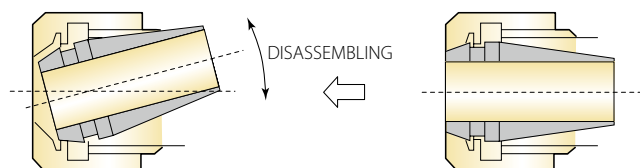



TECHNICAL DATA : SHANK STANDARD

DIN 69871-SK

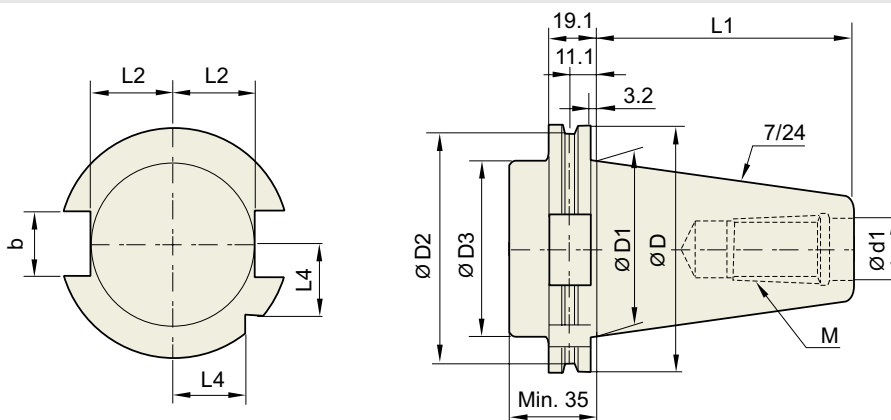

Unit : mm

TAPER No.	ØD	ØD1	ØD2	ØD3	Ød1	L1	L2	L3	L4	b	M
SK30	50	31.75	44.3	45	13	47.8	16.4	19	15	16.1	M12×1.75
SK40	63.55	44.45	56.25	50	17	68.4	22.8	25	18.5	16.1	M16×2.0
SK50	97.5	69.85	91.25	80	25	101.75	35.5	37.7	30	25.7	M24×3.0

JIS B6339/
MAS 403-BT

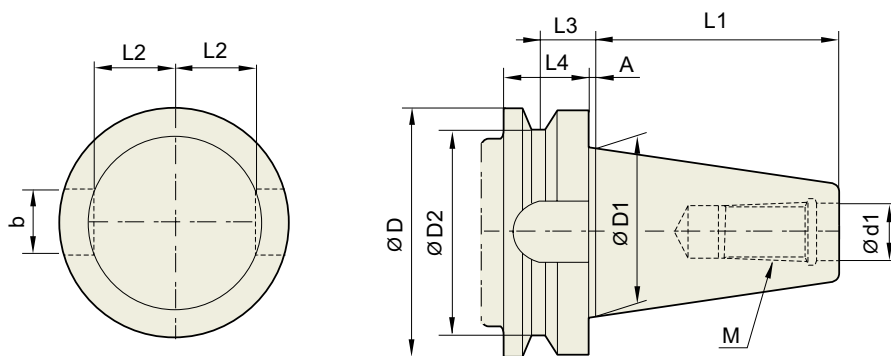

Unit : mm

TAPER No.	ØD	ØD1	ØD2	Ød13.	L1	L2	L3	L4	A	b	M
BT30	46	31.75	38	12.5	48.4	16.3	13.6	20	2	16.1	M12×1.75
BT40	63	44.45	53	17	65.4	22.6	16.6	25	2	16.1	M16×2
BT50	100	69.85	85	25	101.8	35.4	23.2	35	3	25.7	M24×3
BT60	155	107.95	135	31	161.8	60.1	28.2	45	3	25.7	M30×3.5

MODEL NUMBERING SYSTEM & SURFACE FINISH

Model Numbering System

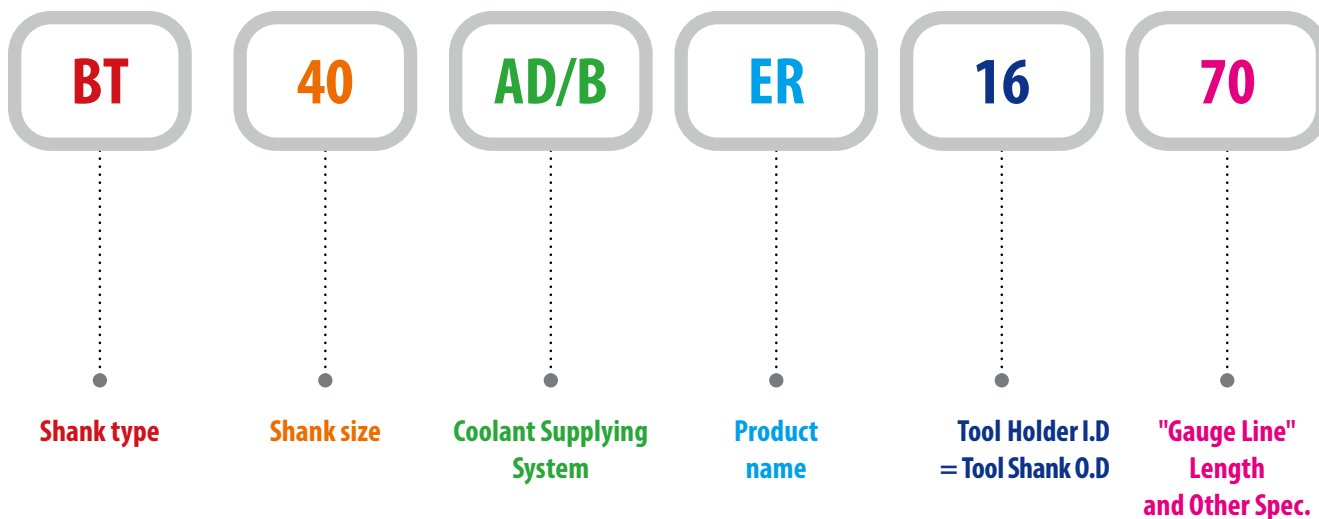

Surface Finish

