



END MILL HOLDER & SIDE LOCK ARBOR

EMH

END MILL HOLDER

DIN 69871-SK

FRÄSERFUTTER UND FLÄCHENSPIANNFUTTER
 MANDRIN PORTE FRAISE À QUEUE CYLINDRIQUE, À MÉPLAT
 MANDRINI PORTA FRESA TIPO WELDON
 PORTAFRESAS Y EJES DE SUJECCION LATERAL

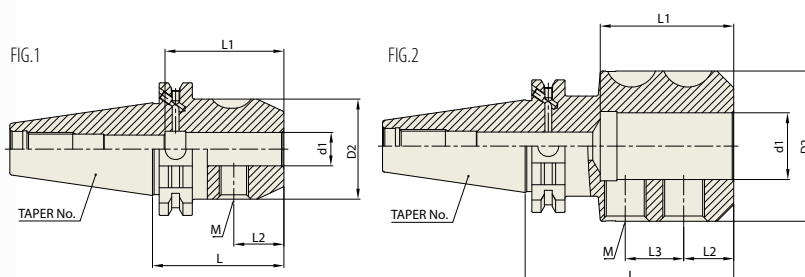

Unit : mm

TAPER No.	MODEL No.	EDP No.	d1	D2	L	L1	L2	L3	M	FIG.	WEIGHT (kg)
40	SK40AD/B-EMH6-50	P2531009	6	25	50	35	18	-	M6	1	0.86
	SK40AD/B-EMH8-50	P2531010	8	28	50	35	18	-	M8	1	0.89
	SK40AD/B-EMH10-50	P2531011	10	35	50	39	20	-	M10	1	0.95
	SK40AD/B-EMH12-50	P2531012	12	42	50	46	22.5	-	M12	1	1.03
	SK40AD/B-EMH16-63	P2531013	16	48	63	57	24	-	M14	1	1.28
	SK40AD/B-EMH20-63	P2531014	20	52	63	54	25	-	M16	1	1.28
	SK40AD/B-EMH25-100	P2531015	25	65	100	60	24	25	M18	2	2.28
	SK40AD/B-EMH32-100	P2531016	32	72	100	64	24	28	M20	2	2.50
50	SK50AD/B-EMH6-63	P2531017	6	25	50	35	18	-	M6	1	2.70
	SK50AD/B-EMH8-63	P2531018	8	28	50	35	18	-	M8	1	2.70
	SK50AD/B-EMH10-63	P2531019	10	35	50	39	20	-	M10	1	2.90
	SK50AD/B-EMH12-63	P2531020	12	42	63	46	22.5	-	M12	1	2.90
	SK50AD/B-EMH16-63	P2531021	16	48	63	49	24	-	M14	1	3.00
	SK50AD/B-EMH20-63	P2531022	20	52	63	52	25	-	M16	1	3.05
	SK50AD/B-EMH25-80	P2531023	25	65	80	60	24	25	M18	2	3.73
	SK50AD/B-EMH32-100	P2531024	32	72	100	64	24	28	M20	2	4.53
	SK50AD/B-EMH40-100	P2531025	40	80	100	74	30	32	M20	2	4.77
	SK50AD/B-EMH50-125	P2531026	50	100	125	84	35	35	M24	2	7.03

- ▶ CAT(ANSI B5.50) taper and Inch type products are available.
- ▶ Standard End Mill Holder is for a cutting tool with Weldon shank and End Mill Holder for a cutting tool with Whistle notch is available upon request.
- ▶ Combi-style holder with ball jointed clamping screw which can be used with cutting tools with Weldon and Whistle notch shank is available.

TOOLING SYSTEM

HYDRAULIC CHUCK

SHRINK FIT HOLDER

ER COLLET CHUCK

END MILL HOLDER & SIDE LOCK ARBOR

SHELL MILL ARBOR

POWER MILLING CHUCK

MORSE TAPER ARBOR

SK SLIM CHUCK

SYNCHRO TAPPING CHUCK

ONE STEP TAPPING CHUCK

TAPPING ER CHUCK

TAPPING CHUCK

FACE MILL ARBOR

COPY MILL ARBOR & INDEXABLE DRILL HOLDER

NC DRILL CHUCK & OTHER TOOL HOLDERS

BORING SYSTEM

ACCESSORY & OTHERS

TECHNICAL DATA : SHANK STANDARD

DIN 69871-SK

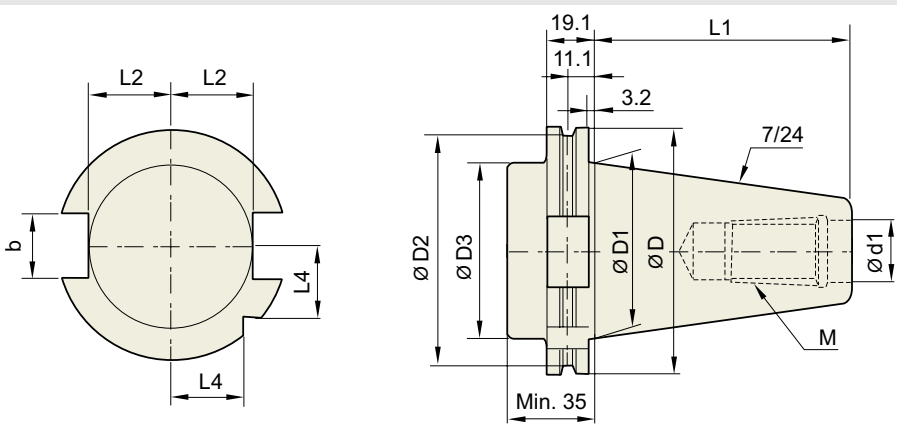

Unit : mm

TAPER No.	ØD	ØD1	ØD2	ØD3	Ød1	L1	L2	L3	L4	b	M
SK30	50	31.75	44.3	45	13	47.8	16.4	19	15	16.1	M12×1.75
SK40	63.55	44.45	56.25	50	17	68.4	22.8	25	18.5	16.1	M16×2.0
SK50	97.5	69.85	91.25	80	25	101.75	35.5	37.7	30	25.7	M24×3.0

JIS B6339/ MAS 403-BT

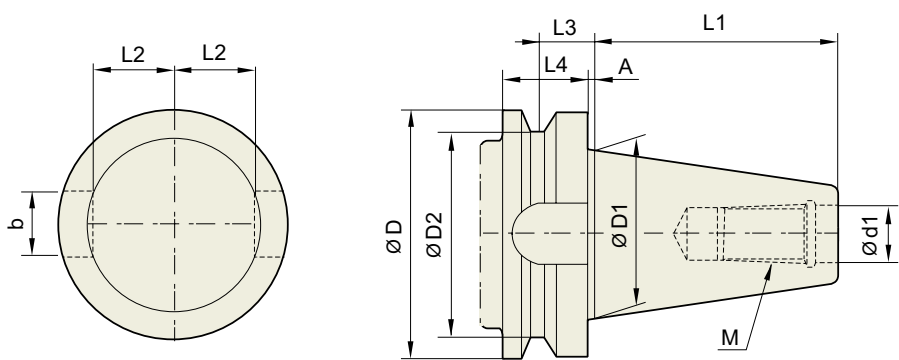

Unit : mm

TAPER No.	ØD	ØD1	ØD2	Ød13.	L1	L2	L3	L4	A	b	M
BT30	46	31.75	38	12.5	48.4	16.3	13.6	20	2	16.1	M12×1.75
BT40	63	44.45	53	17	65.4	22.6	16.6	25	2	16.1	M16×2
BT50	100	69.85	85	25	101.8	35.4	23.2	35	3	25.7	M24×3
BT60	155	107.95	135	31	161.8	60.1	28.2	45	3	25.7	M30×3.5

MODEL NUMBERING SYSTEM & SURFACE FINISH

Model Numbering System

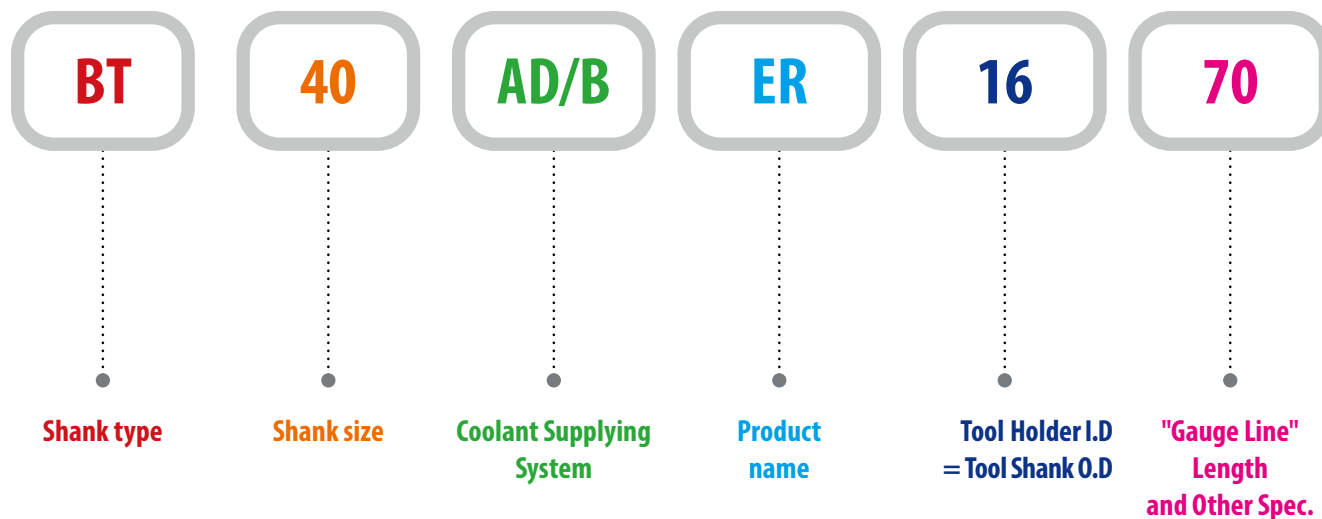

Surface Finish

