

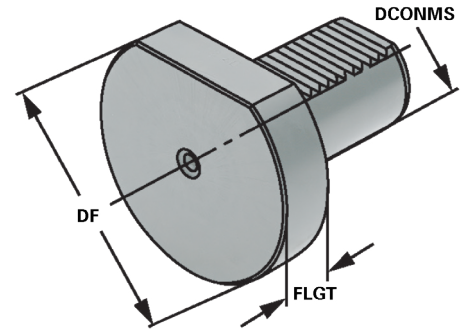

Verwendung:
Zum Verschließen der Aufnahmebohrung
am Werkzeugrevolver.

Application:
For sealing the spindle of the turret.

Application:
Pour boucher la broche du tour.



DIN ISO
10889

Z2

Bestell-Nr. Order no. Référence	Abmessung Size Dimension	DCONMS	DF	FLGT
169.29.13	Z2 - 16 × 13	16	40	13
209.29.16	Z2 - 20 × 16	20	50	16
259.29.16	Z2 - 25 × 16	25	58	16
309.29.20	Z2 - 30 × 16	30	68	16
409.29.20	Z2 - 40 × 20	40	83	20
509.29.20	Z2 - 50 × 20	50	98	20





Example:

40 3 . 02 . 20 . 1

