



Quick change tapping chucks **with** length compensation on compression and expansion

Mandrins de taraudage à changement rapide **avec** compensation longitudinale à la compression et traction

2



Verwendung:

Zur Aufnahme von Schnellwechsel-Ein-sätzen für Gewindebohrer.

Application:

For the chucking of quick change adaptors for taps.

Application:

Pour le serrage d'adaptateurs porte-tarauds à changement rapide.

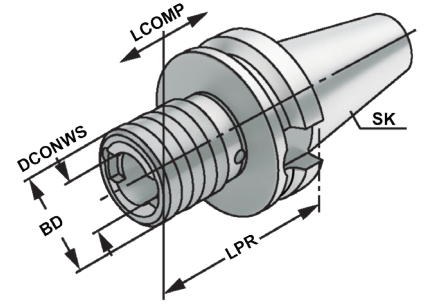

Bestell-Nr. Order no. Référence	SK	Spannbereich Capacity Capacité	SZID	DCONWS	LPR	BD	LCOMP
305.16.12	BT 30	M3 - M14	1	19	64	36	7
305.16.20	BT 30	M5 - M22	2	31	95	53	12
405.16.12	BT 40	M3 - M14	1	19	65	36	7
405.16.20	BT 40	M5 - M22	2	31	93	53	12
405.16.36	BT 40	M14 - M36	3	48	166	78	20
505.16.12	BT 50	M3 - M14	1	19	100	36	7
505.16.20	BT 50	M5 - M22	2	31	105	53	12
505.16.36	BT 50	M14 - M36	3	48	142	78	17,5

Hinweis: Für Bearbeitungszentren ohne Synchronspindel.
Note: For machining centres without synchronous spindle.
Observation: Pour centres d'usinage sans broche synchrone.



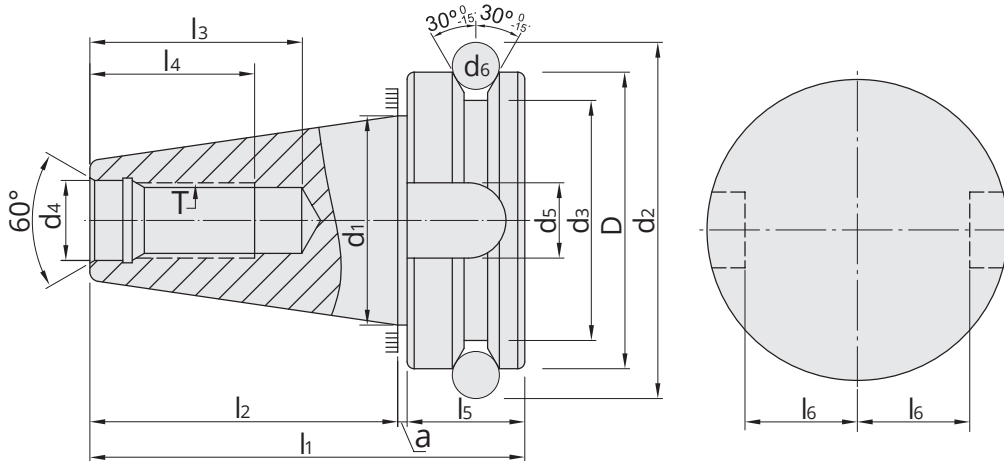

SK	D	d ₁	d ₂	d ₃	d ₄	d ₅	d ₆	d ₉	a	l ₁	l ₂	l ₃	l ₄	l ₅	l ₆	e ₁	e ₂	T
	H8				H8	H12		H12	±0,4		±0,2	min	min		⁰ _{-0,2}	±0,1	max	
30	46	31,75	56,14	38	12,5	16,1	8	-	2	70,4	48,4	34	24	20	16,3	-	-	M12
40	63	44,45	75,679	53	17	16,1	10	4	2	92,4	65,4	43	30	25	22,6	27	5	M16
50	100	69,85	119,02	85	25	25,7	15	6	3	139,8	101,8	62	45	35	35,4	42	7	M24

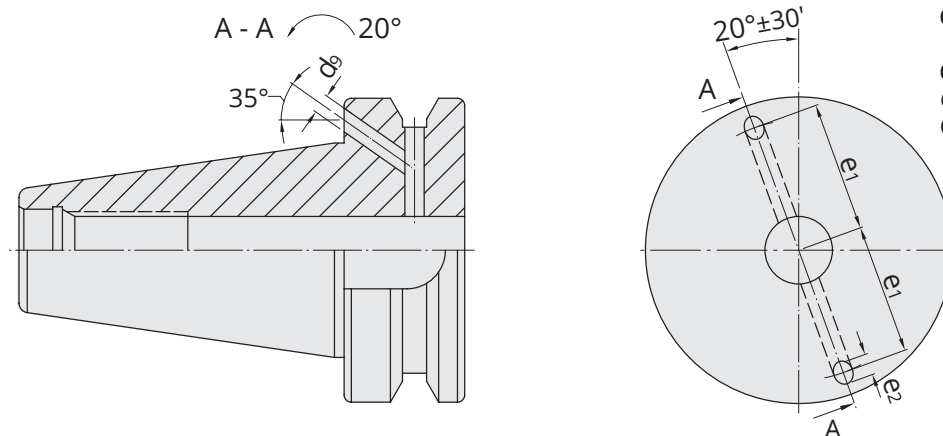
Mit innerer Kühlmittelzufuhr über den Bund - Form JD/JF (AD/B)
With internal coolant through the collar - form JD/JF (AD/B)
Avec arrosage interne par la collerette - forme JD/JF (AD/B)
Vorgewuchtet
Pre-balanced
Pré-équilibré
G 6,3 15.000 min⁻¹
G 2,5 Feinwuchten gegen Aufpreis
G 2.5 Fine balancing at extra charge
G 2,5 Equilibrage fin contre un supplément

Werkstoff: Legierter Einsatzstahl mit einer Zugfestigkeit im Kern von min. 950 N / mm². Einsatzgehärtet HRC 60 ± 2 (HV 700 ± 50), Härtetiefe 0,8 mm ± 0,2 mm, brüniert und präzisionsgeschliffen.

Form JD/JF: Lieferung in Ausführung JD (AD), Form JF (B) mit lösbaren Gewindestiften verschlossen.

Genauigkeit: Kegelwinkel - Toleranzqualität < AT 3 nach DIN 7187 und DIN 2080.

Material: *Alloyed case-hardened steel, tensile core strength of min. 950 N / mm². Case hardened HRC 60 ± 2 (HV 700 ± 50), hardening depth 0.8 mm ± 0.2 mm, black-finished and precisely grinded.*

Form JD/JF: *Delivery in form JD (AD), form JF (B) closed with releasable headless screws.*

Accuracy: *Quality of taper < AT 3 according to DIN 7187 and DIN 2080.*

Matière: Acier de cémentation allié. Résistance à la traction dans le noyau de min 950 N / mm². Cémentation à HRC 60 ± 2 (HV 700 ± 50), profondeur de cémentation 0,8 mm ± 0,2 mm, bruni et rectifié précisément.

Forme JD/JF: Livraison en forme JD (AD), forme JF (B) fermée avec des vis amovibles sans tête.

Précision: Qualité du cône < AT 3 selon DIN 7187 et DIN 2080.



Example:

40 3 . 02 . 20 . 1





The process of tapping is a complex balance of rotational and axial movements of the tool. It is sometimes necessary to restrict the axial movements of the tool.

If the axial movement is not accurately controlled, the leading or trailing flanks of the tap may be forced to progressively “shave” one flank of the component thread, thus producing a thin and oversize thread in the component.

Tension – forward float capability allows the tap to progress into the component without interference from the axial feed of the machine spindle.

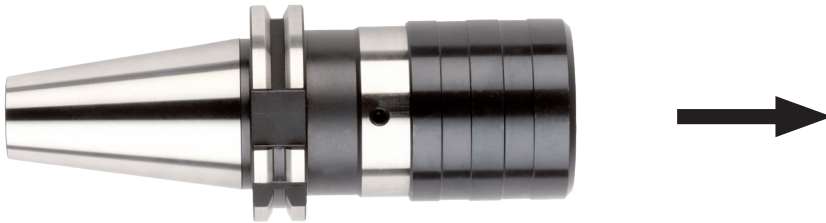

Compression – backward float capability, acts as a cushion and allows the tap to commence cutting at its own axial feed independent of the machine spindle.

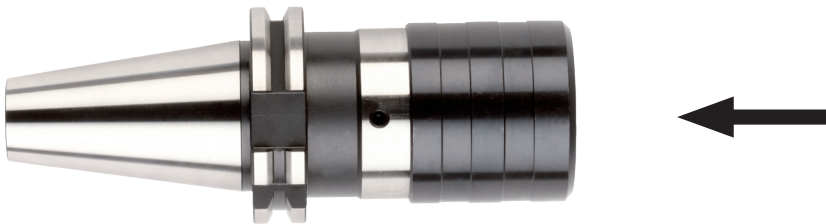

Compression/Tension – float is designed to negate any external forces during the machining operation.

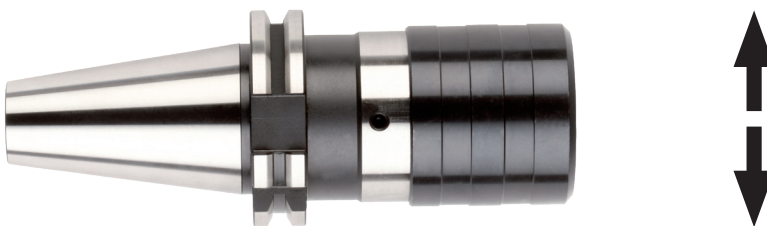

Radial float – allows for slight misalignment of the machine spindle axis and hole axis prior to tapping. This is not recommended manufacturing practice and should be avoided.

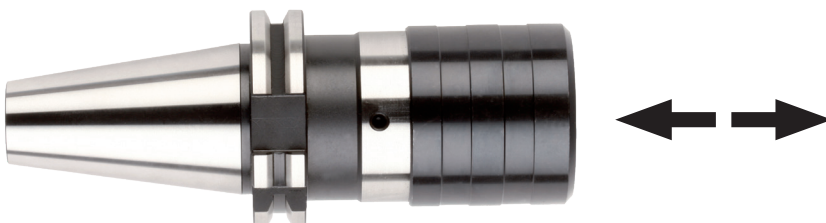



For a correct use of the tapping chuck, please check, during the first thread, not to exceed the max. axial stroke of the compensation values. This is to avoid damaging the thread or the tapping chuck.



Adjustment screw for amplification of chamfer edge pressure. Turning the screw clockwise amplifies the chamfer edge pressure.

Compensation in compression



Compensation in extension

Code	Tap capacity	Adapters	Length adjustment in mm on	
			Compression	Extension
xxx.16.12	M 3 - M14	16.11.xx / 16.01.xx	7	7
xxx.16.20	M 5 - M22	16.12.xx / 16.02.xx	12	12
xxx.16.36	M14 - M36	16.14.xx / 16.03.xx	17.5	17.5