

Quick change tapping chucks with length compensation on compression and expansion
Mandrins de taraudage à changement rapide avec compensation longitudinale à la compression et traction



Verwendung:
 Zur Aufnahme von Schnellwechsel-Einsätzen für Gewindebohrer.

Application:
 For the chucking of quick change adaptors for taps.

Application:
 Pour le serrage d'adapteurs porte-tarauds à changement rapide.

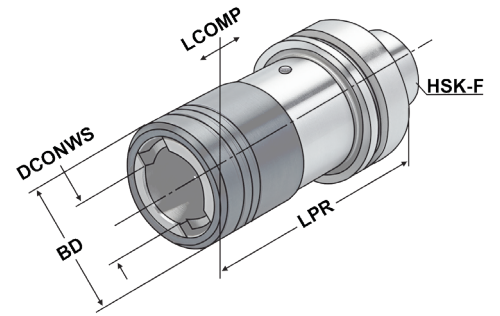

5

Bestell-Nr. Order no. Référence	HSK	Spannbereich Capacity Capacité	SZID	DCONWS	LPR	BD	LCOMP
F63.16.12	HSK-F 63	M3 - M14	1	19	102	36	7
F63.16.20	HSK-F 63	M5 - M22	2	31	140	53	12

Hinweis: Für Bearbeitungszentren ohne Synchronspindel.
Note: For machining centres without synchronous spindle.
Observation: Pour centres d'usinage sans broche synchrone.



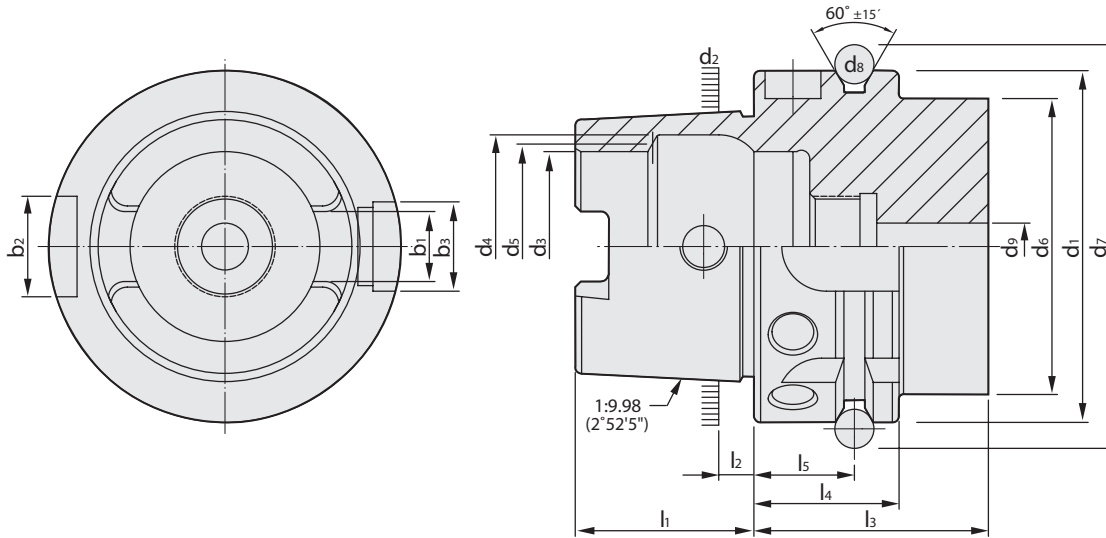

5

HSK	d ₁	d ₂	d ₃	d ₄	d ₅	d ₆	d ₇	d ₈	d ₉	l ₁	l ₂	l ₃	l ₄	l ₅	b ₁	b ₂	b ₃
	h10		H10	H11		max	⁰ _{-0,1}		max	⁰ _{-0,2}		min	⁰ _{-0,1}	±0,1	±0,04	H10	H10
25	25	19,006	14	16,4	15	20	28,5	3	3	13	2,5	20	10	4,5	6,05	6	7
32	32	24,007	17	20,5	19	26	37	4	4,2	16	3,2	35	20	16	7,05	7	9
40	40	30,007	21	25,5	23	34	45	4	5	20	4	35	20	16	8,05	9	11
50	50	38,009	26	32	29	42	59,3	7	6,8	25	5	42	26	18	10,54	12	14
63	63	48,010	34	40	37	53	72,3	7	8,4	32	6,3	42	26	18	12,54	16	18
80	80	60,012	42	50	46	68	88,8	7	10,2	40	8	42	26	18	16,04	18	20
100	100	75,013	53	63	58	88	109,75	7	12	50	10	45	29	20	20,02	20	22
125	125	95,016	67	80	73	111	134,75	7	14	63	12,5	45	29	20	25,02	25	28

Vorgewuchtet G 6,3 15.000 min-1
 Pre-balanced G 6,3 15.000 min-1
 Pré-équilibré G 6,3 15.000 min-1

G 2,5 Feinwuchten gegen Aufpreis
 G 2.5 Fine balancing at extra charge
 G 2,5 Equilibrage fin contre un supplément

Werkstoff: Legierter Einsatzstahl mit einer Zugfestigkeit im Kern von min. 950 N / mm². Einsatzgehärtet HRC 60 ± 2 (HV 700 ± 50), Härtetiefe 0,8 mm ± 0,2 mm, brüniert und präzisionsgeschliffen.

Material: Alloyed case-hardened steel, tensile core strength of min. 950 N / mm². Case hardened HRC 60 ± 2 (HV 700 ± 50), hardening depth 0.8 mm ± 0.2 mm, black-finished and precisely grinded.

Matière: Acier de cémentation allié. Résistance à la traction dans le noyau de min 950 N / mm². Cémentation à HRC 60 ± 2 (HV 700 ± 50), profondeur de cémentation 0,8 mm ± 0,2 mm, bruni et rectifié précisément.

Normative Verweise:

ISO 12164-1:2001-12
 Hohlkegelschnittstelle mit Plananlage
 - Teil 1: Schäfte; Maße

Normative references:

ISO 12164-1:2001
 Hollow taper interface with flange contact surface
 - Part 1: Shanks; Dimensions

Références normatives:

ISO 12164-1:2001
 Interfaces à cône creux-face
 - Partie 1: Queues; Dimensions

DIN 69893-1:2011
 Kegel-Hohlschäfte mit Plananlage besteht aus:
 - Teil 1: Kegel-Hohlschäfte Form A und Form C;
 Maße und Ausführung

DIN 69893-1:2011
 Hollow taper shanks with flange contact surface:
 - Part 1: Hollow taper shanks type A and type C;
 Dimensions and design

DIN 69893-1:2011
 Queues creuses coniques à surface de contact plane:
 - Partie 1: Queues creuses coniques type A et type C;
 Dimensions et conception



Example:

40 3 . 02 . 20 . 1





The process of tapping is a complex balance of rotational and axial movements of the tool. It is sometimes necessary to restrict the axial movements of the tool.

If the axial movement is not accurately controlled, the leading or trailing flanks of the tap may be forced to progressively “shave” one flank of the component thread, thus producing a thin and oversize thread in the component.

Tension – forward float capability allows the tap to progress into the component without interference from the axial feed of the machine spindle.

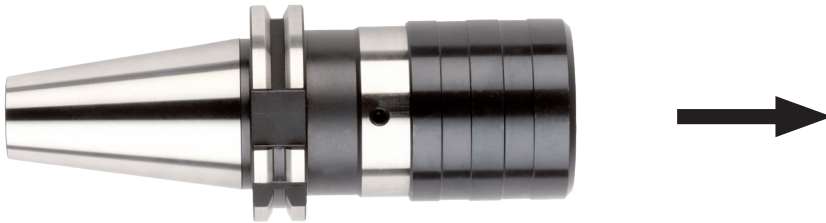

Compression – backward float capability, acts as a cushion and allows the tap to commence cutting at its own axial feed independent of the machine spindle.

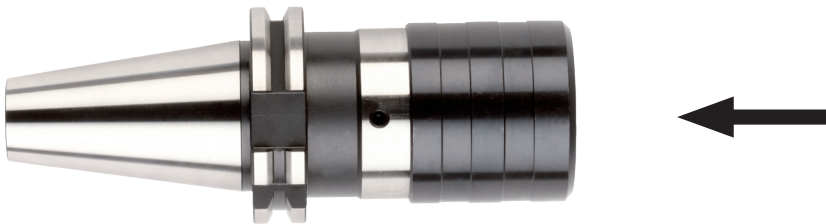

Compression/Tension – float is designed to negate any external forces during the machining operation.

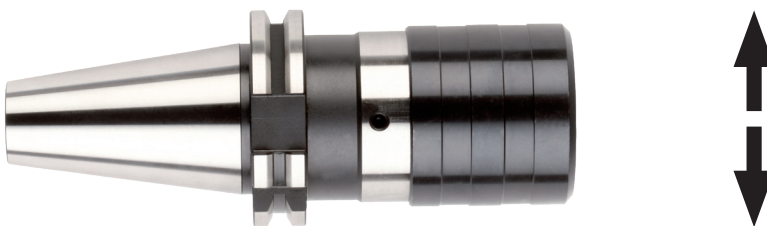

Radial float – allows for slight misalignment of the machine spindle axis and hole axis prior to tapping. This is not recommended manufacturing practice and should be avoided.

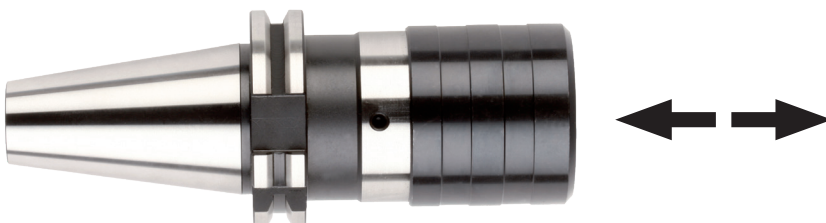



For a correct use of the tapping chuck, please check, during the first thread, not to exceed the max. axial stroke of the compensation values. This is to avoid damaging the thread or the tapping chuck.



Adjustment screw for amplification of chamfer edge pressure. Turning the screw clockwise amplifies the chamfer edge pressure.

Compensation in compression



Compensation in extension

Code	Tap capacity	Adapters	Length adjustment in mm on	
			Compression	Extension
xxx.16.12	M 3 - M14	16.11.xx / 16.01.xx	7	7
xxx.16.20	M 5 - M22	16.12.xx / 16.02.xx	12	12
xxx.16.36	M14 - M36	16.14.xx / 16.03.xx	17.5	17.5