



Quick change tapping chucks **with** length compensation on compression and expansion

Mandrins de taraudage à changement rapide **avec** compensation longitudinale à la compression et traction



Verwendung:

Zur Aufnahme von Schnellwechsel-Einsätzen für Gewindebohrer.

Application:

For the chucking of Quick change taps for threading taps.

Application:

Pour le serrage des inserts de changement rapide pour tarauds.

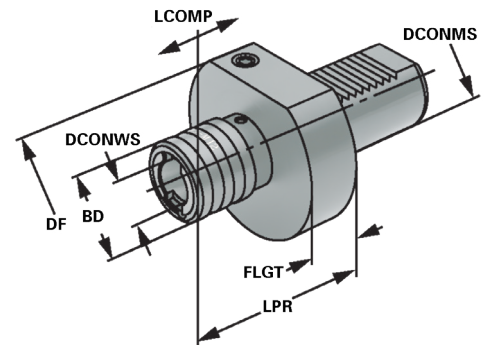

Bestell-Nr. Order no. Référence	DCONMS	Spannbereich Capacity Capacité	SZID	DF	LPR	BD	DCONWS	LCOMP	FLGT
209.16.12	20	M3 - M14	1	50	67	38	19	7	17
259.16.12	25	M3 - M14	1	58	55	38	19	7	18
309.16.12	30	M3 - M14	1	68	58	36	19	7	22
309.16.20	30	M5 - M22	2	68	81	53	31	12	22
409.16.12	40	M3 - M14	1	83	58	36	19	7	22
409.16.20	40	M5 - M22	2	83	81	53	31	12	22
509.16.12	50	M3 - M14	1	98	56	36	19	7	30
509.16.20	50	M5 - M22	2	98	80	53	31	12	30

7



10.42



10.43



10.48

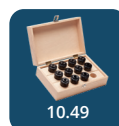

10.49



10.50



7.50



7.55

Toolholders DIN ISO 10889 (formerly DIN 69880 / VDI 3425)
 Porte-outils DIN ISO 10889 (l'ancien DIN 69880 / VDI 3425)

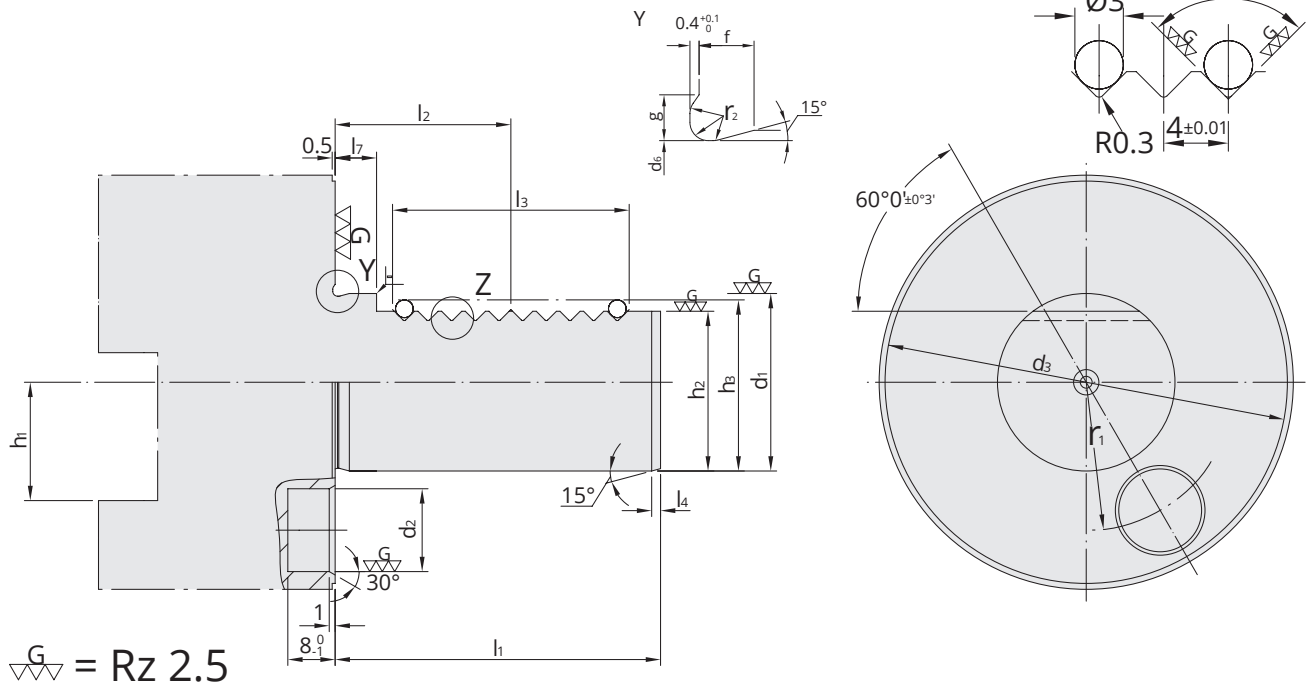

$\sqrt{\text{G}} = \text{Rz } 2,5$

d_1 h_6	b	h_1 max.	d_2	d_3	h_2 $\pm 0,1$	r $\pm 0,02$	l_1 max.	l_2 $\pm 0,05$	l_3 max.	l_4 max.	l_5
16	42	12	8	40	15,0	14,5	32	12,7	16	2	3,5
20	52	16	10	50	18,0	18,0	40	21,7	24	2	7,0
25	60	16	10	58	23,5	21,0	48	21,7	24	2	7,0
30	70	20	14	68	27,0	25,0	55	29,7	40	2	7,0
40	85	25	14	83	36,0	32,0	63	29,7	40	3	7,0
50	100	32	16	98	45,0	37,0	78	35,7	48	3	8,0

Werkstoff: Legierter Einsatzstahl mit einer Zugfestigkeit im Kern von min. 950 N / mm². Einsatzgehärtet HRC 60 ± 2 (HV 700 ± 50), Härtetiefe 0,8 mm ± 0,2 mm, brüniert und präzisionsgeschliffen.

Ausführung: Mit innerer Kühlmittelzufuhr bzw. mit Gewindeanschluss für externe Kühlmittelzufuhr.

Material: Alloyed case-hardened steel, tensile core strength of min. 950 N / mm². Case hardened HRC 60 ± 2 (HV 700 ± 50), hardening depth 0.8 mm ± 0.2 mm, black-finished and precisely grinded.

Version: With internal coolant resp. with threaded connection for external coolant.

Matière: Acier de cémentation allié. Résistance à la traction dans le noyau de min 950 N / mm². Cémentation à HRC 60 ± 2 (HV 700 ± 50), profondeur de cémentation 0,8 mm ± 0,2 mm, bruni et rectifié précisément.

Version: Avec arrosage interne respectivement avec raccord fileté pour arrosage externe.

Werkzeugzuordnung für Scheibenrevolver

Tool assignment for disc turrets

Assignation des outils pour machines avec tourelle à disque

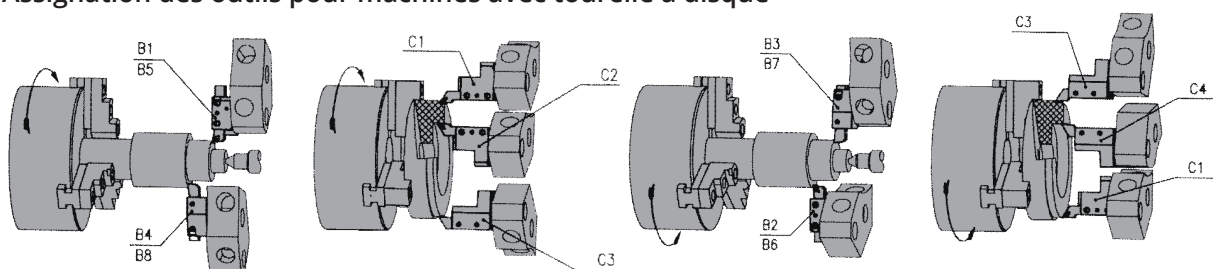

Einsatz von Werkzeughaltern bei linker Spindeldrehrichtung
 Application of tool holders with anti-clockwise spindle rotation
 Utilisation d'attachements avec la broche en sens anti-horaire

Einsatz von Werkzeughaltern bei rechter Spindeldrehrichtung
 Application of tool holders with clockwise spindle rotation
 Utilisation d'attachements avec la broche en sens horaire



Example:

40 3 . 02 . 20 . 1

