



Schnellwechsel-Einsätze ohne Sicherheitskupplung, Größe 1

Quick change adaptors without safety clutch, size 1

Adaptateurs à changement rapide sans limiteur de couple, taille 1



Verwendung:

Zur Spannung von Gewindebohrern.
Für Rechts- und Linksgewinde. Standardausführung ohne Sicherheitskupplung.

Application:

For mounting taps. For right-hand and left-hand threads. Standard type without safety clutch.

Application:

Pour le serrage de tarauds. Pour taraudage à droite et à gauche. Modèle standard sans limiteur de couple.

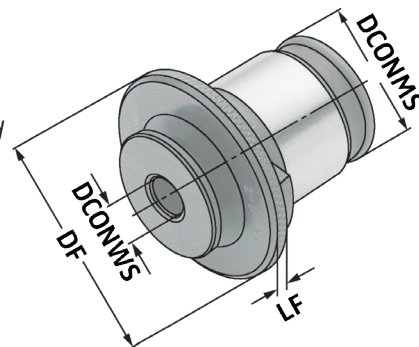

Bestell-Nr. Order no. Référence	SZID	DCONMS	DCONWS	DRVS	DIN371	DIN 374 / 376	DF	LF
16.01.2821	1	19	2,8	2,1	M2-M2,6	-	30	4
16.01.3527	1	19	3,5	2,7	M3	-	30	4
16.01.43	1	19	4,0	3,0	M3,5	-	30	4
16.01.4534	1	19	4,5	3,4	M4	-	30	4
16.01.649	1	19	6,0	4,9	M4,5-M6	M8	30	4
16.01.755	1	19	7,0	5,5	M7	M10	30	4
16.01.862	1	19	8,0	6,2	M8	M11	30	4
16.01.97	1	19	9,0	7,0	M9	M12	30	4
16.01.108	1	19	10,0	8,0	M10	-	30	4
16.01.119	1	19	11,0	9,0	-	M14	30	4



10.48

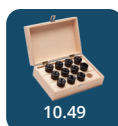

10.49



10.50

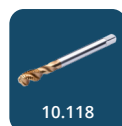

10.118



Example:

40 3 . 02 . 20 . 1

