

mit zentrischer innerer Kühlmittel-Zufuhr | ehemals JIS B 6339 (MAS 403 BT)

Pull studs ISO 7388-3 | shank form JD | for centric inner cooling lubricant supply | formerly JIS B 6339
 Tirettes ISO 7388-3 | forme JD | avec arrosage interne centré | l'ancien JIS B 6339 (MAS 403 BT)

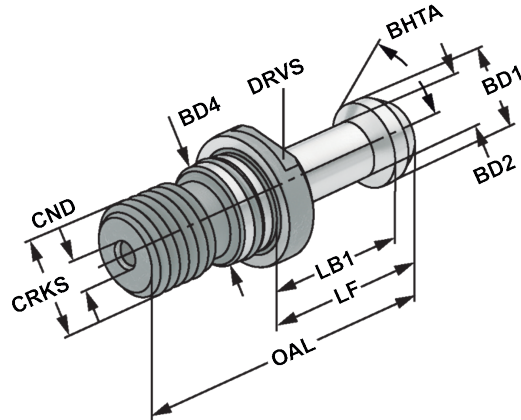

Bestell-Nr. Order no. Référence	CRKS	BHTA	OAL	LF	LB1	BD1	BD2	BD4	CND	DRVS
306.20.45	M12	45°	43	23	18	11	7	12,5	2,5	13
306.20.60	M12	60°	43	23	18	11	7	12,5	2,5	13
406.20.45	M16	45°	60	35	28	15	10	17,0	4,0	19
406.20.60	M16	60°	60	35	28	15	10	17,0	4,0	19
406.20.90	M16	90°	60	35	28	15	10	17,0	4,0	19
506.20.45	M24	45°	85	45	35	23	17	25,0	6,0	30
506.20.60	M24	60°	85	45	35	23	17	25,0	6,0	30
506.20.90	M24	90°	85	45	35	23	17	25,0	6,0	30

Form JD | mit Durchgangsbohrung | inkl. O-Ring
 Form JD | with drill through | incl. O-ring
 Forme JD | percée | avec joint torique

Verwendung:
 Für Werkzeuge mit Steilkegelschaft ISO 7388-2 (ehemals JIS B 6339 MAS-BT)

Application:
 For tools with taper shanks ISO 7388-2 (formerly JIS B 6339 MAS-BT)

Utilisation:
 Pour les outils avec queue conique ISO 7388-2 (l'ancien JIS B 6339 MAS-BT)





Drehmomentschlüssel

Universal Torque Wrenches
Clés dynamométriques



Verwendung:
Zur Übertragung eines definierten Anzugsmomentes.

Application:
For the transfer of a defined torque.

Application:
Pour la transmission d'un couple de serrage défini.

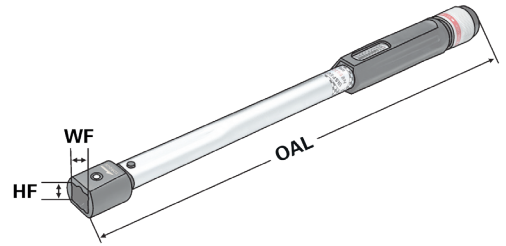

Bestell-Nr. Order no. Référence	Drehmoment Torque Couple	OAL	WF	HF
800.010	20 – 100 Nm	430	18	14
800.030	60 – 300 Nm	580	18	14

Maul-Einsteckwerkzeug für Spannmuttern System ER, mit Sechskant

Open jaw plug-in head for clamping nuts ER-system, with hexagon

Embout à fourche pour clés dynamométriques pour écrous de serrage système ER, avec hexagone

10



Verwendung:
Zur Übertragung eines definierten Anzugsmomentes.

Application:
For the transfer of a defined torque.

Application:
Pour la transmission d'un couple de serrage défini.

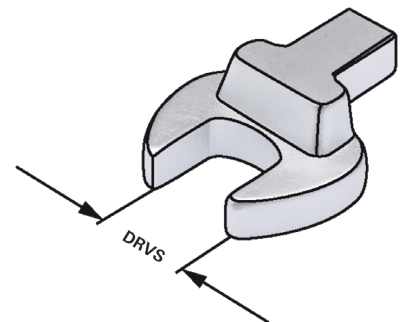

ISO
15488

Bestell-Nr. Order no. Référence	Ausführung Version Type	DRVS	WF	HF
800.02.10	426E ER 16	25	18	14
800.02.10.2	426E ER 16	27	18	14
800.02.13.1	428E ER 20	30	18	14

Plug-in head for system HKS

Embout pour clés dynamométriques pour système HKS



Verwendung:
Zur Übertragung eines definierten Anzugsmomentes.

Application:
For the transfer of a defined torque.

Application:
Pour la transmission d'un couple de serrage défini.

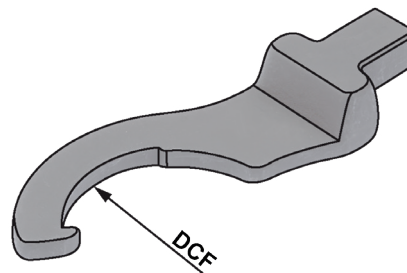

Bestell-Nr. Order no. Référence	Ausführung Version Type	DCF	WF	HF
800.64.20	HKS 20	50	18	14
800.64.32	HKS 25 + HKS 32	60	18	14

Maul-Einsteckwerkzeug für Anzugsbolzen

Open jaw plug-in head for Pull studs

Embout à fourche pour tirettes



Verwendung:
Zur Übertragung eines definierten Anzugsmomentes.

Application:
For the transfer of a defined torque.

Application:
Pour la transmission d'un couple de serrage défini.

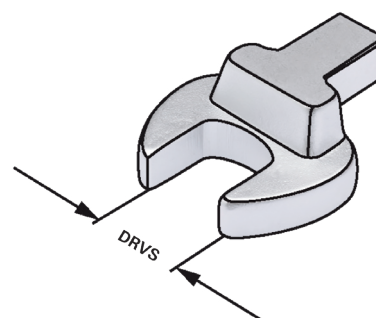

10

Bestell-Nr. Order no. Référence	Ausführung Version Type	DRVS	WF	HF
800.20.13	BT 30	13	18	14
800.20.14	SK 30	14	18	14
800.20.19	SK / BT 40	19	18	14
800.20.30	SK / BT 50	30	18	14

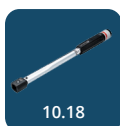



Large manual machines and CNC machines use toolholders that have been precisely ground with a male taper that mates with the machine's specific female taper. There is also a way to secure the toolholder in place with a pull stud or a draw bar thread. With CNC machines, the pull stud is more popular because it allows for easier automatic tool changing.

A toolholder consists of five basic components:

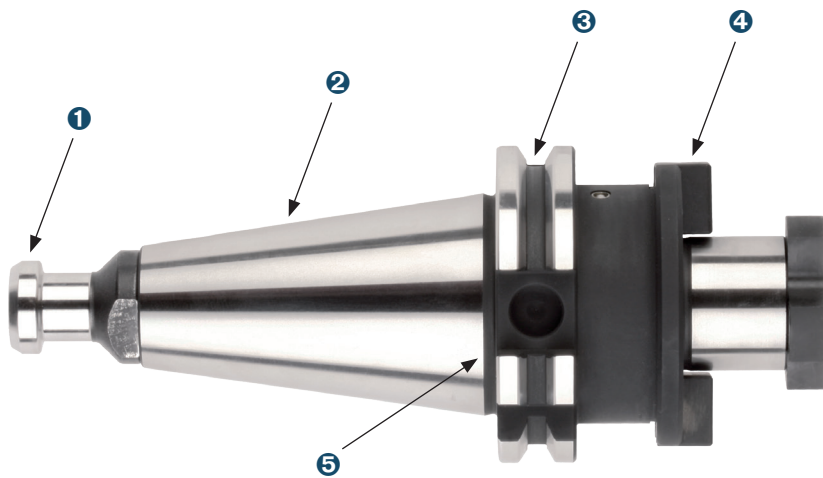

- ❶ Pull Stud
- ❷ Tapered Shank
- ❸ Gripper groove: circular groove
- ❹ Adapter
- ❺ Opposed Slot

Tapered shank

The standard defines six basic taper shank sizes including SK 30, SK 35, SK 40, SK 45, SK 50, and SK 60.

The proper Taper Shank for the Type of Machine

- ISO 60 Very large machines
- ISO 50 Medium size machines
- ISO 40 Small size machines
- ISO 30 Very small machines

Coolant supply form AD/B

Toolholders form AD/B have internal coolant supply. To use form B (coolant supply through the collar) the two headless screws must be removed and a sealed pull stud must be inserted. To use form AD (central coolant supply) the two headless screws must remain at the collar and a pull stud with drill through must be inserted.

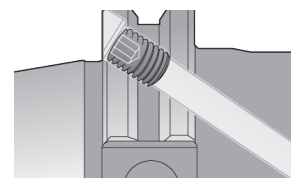



Pull studs are an important link between machine and tool.
The tightening bolt allows the clamping gripper of the spindle to pull the tool holder firmly into the spindle and eject it automatically.

Pull studs / Retention knobs come in different designs and sizes. They are not interchangeable. In addition to the pull studs according to DIN ISO 7388-3 (formerly DIN 69872), there are a variety of factory standards specified by the respective machine tool manufacturer.

Application:

- For tools with steep taper shank ISO 7388-1 and ISO 7388-2 [formerly DIN 69871 and JIS B 6339 (MAS-BT)]
- In machining centres (machines with automatic tool changer)
- In NC machines (machines without automatic tool changer)
- For tools with axial coolant supply
- For tools with or without axial coolant supply

Only use the pull studs that are specified by the machine tool manufacturer.

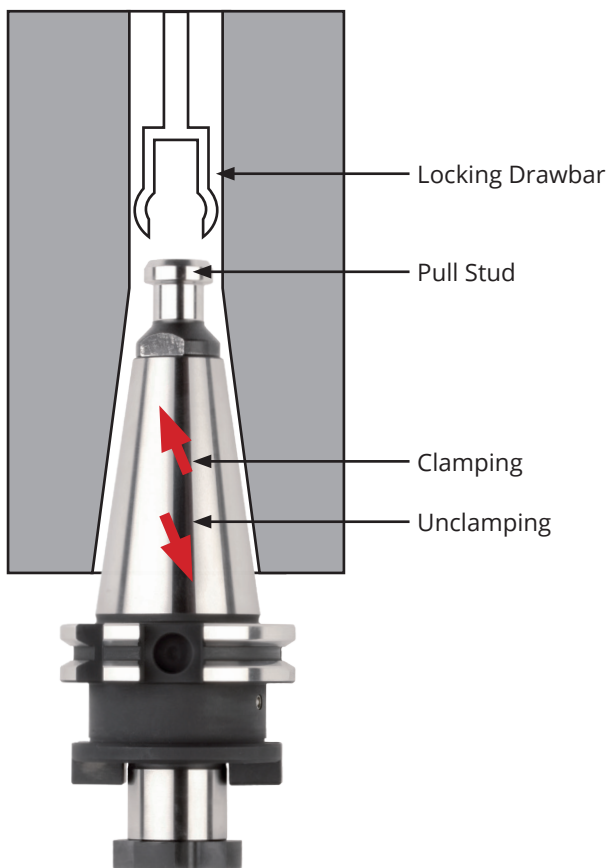

Recommended torque for pull stud tightening:

SK / BT / ISO 30	20 Nm
SK / BT / ISO 40	50 Nm
SK / BT / ISO 50	100 Nm



Normative references:

DIN ISO 7388 consists of the following parts, under the general title Tool shanks with 7/24 taper for automatic tool changers:

- Part 1: Dimensions and designation of shanks of forms A, AD, AF, U, UD and UF
- Part 2: Dimensions and designation of shanks of forms J, JD, and JF
- Part 3: Retention knobs for shanks of forms AC, AD, AF, UC, UD, UF, JD, and JF

DIN ISO 7388-3

Tool shanks with 7/24 taper for automatic tool changers – Part 3: Retention knobs for shanks of forms AC, AD, AF, UC, UD, UF, JD and JF (ISO 7388-3:2013), English translation of DIN ISO 7388-3:2015-03

DIN ISO 7388-3 is a replacement for DIN 69872:1988-07