



Tapping chucks for synchronisation for collets DIN 6499 (ISO 15488) ER-system

Mandrins de taraudage pour synchronisation pour pinces DIN 6499 (ISO 15488) système ER

1



Verwendung:

Für Bearbeitungszentren mit Synchronspindel.

Application:

For machining centres with synchronous spindle.

Application:

Pour centres d'usinage avec la broche synchrone.

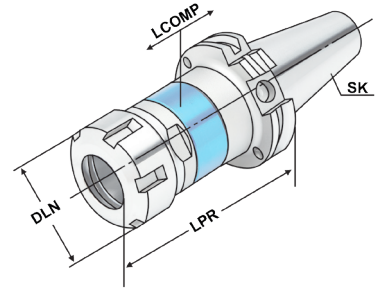

Bestell-Nr. Order no. Référence	SK	DCONWS Spannbereich Capacity Capacité	Typ	LPR	DLN	LCOMP
403.16.02.10 ¹	SK 40	M3 – M12	426E ER 16 SW25	79	28	0,5
403.16.02.10.M ²	SK 40	M3 – M12	426E ER 16 Mini	79	22	0,5
403.16.02.13	SK 40	M3 – M16	428E ER 20	80	34	0,5
403.16.02.16	SK 40	M3 – M20	430E ER 25	84	42	0,5
403.16.02.20	SK 40	M3 – M27	470E ER 32	95	50	0,5
403.16.02.26	SK 40	M3 – M33	472E ER 40	120	63	0,5
503.16.02.10 ¹	SK 50	M3 – M12	426E ER 16 SW25	79	28	0,5
503.16.02.10.M ²	SK 50	M3 – M12	426E ER 16 Mini	79	22	0,5
503.16.02.10.1.M ²	SK 50	M3 – M12	426E ER 16 Mini	90	22	0,5
503.16.02.13	SK 50	M3 – M16	428E ER 20	80	34	0,5
503.16.02.16	SK 50	M3 – M20	430E ER 25	84	42	0,5
503.16.02.20	SK 50	M3 – M27	470E ER 32	95	50	0,5
503.16.02.26	SK 50	M3 – M33	472E ER 40	105	63	0,5

¹ Sechskantmutter

¹ Hexagonal clamping nut

¹ Écrous hexagonal

² Minimutter

² Mini nut

² Écrous mini

Hinweis:

- Synchro-Gewindeschneidfutter kompensieren Synchronisationsfehler.
- Minimallängenausgleich in Druck- und Zugrichtung zwischen Synchronspindel und Gewindebohrer reduziert zu hohe Gewindeflankenreibungskräfte.
- Reduziert eventuelle Axialkraftherhöhung während des Schneidzyklus auf ein Minimum.
- Geeignet für Innenkühlung.
- Kühlmitteldruck max. 100 bar.

Note:

- Synchro tapping chucks compensate synchronisation errors.
- Minimal length compensation on compression and expansion balances very small pitch differences between synchro spindle and tap, which can cause high frictional forces on the thread flanks.
- A possible increase of axial force during the tapping process is reduced to a minimum.
- Suitable for internal coolant.
- Coolant pressure up to max. 100 bar.

Remarque:

- Les mandrins de taraudage synchro corrigent les erreurs commises lors de la synchronisation.
- La compensation de longueur minimale vers la compression et la traction entre la broche synchrone et le taraud réduit les forces de frottement qui sont trop élevées sur les flancs du filet.
- Réduit à min. l'augmentation potentielle de la force axiale pendant le coupage.
- Convient pour le refroidissement interne.
- La pression du liquide d'arrosage max. 100 bar.

Lieferumfang:

Mit gewichteter Spannmutter

Delivery:

With balanced clamping nut

Livraison:

Avec écrou de serrage équilibré

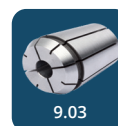

9.03



10.24



10.51



10.26

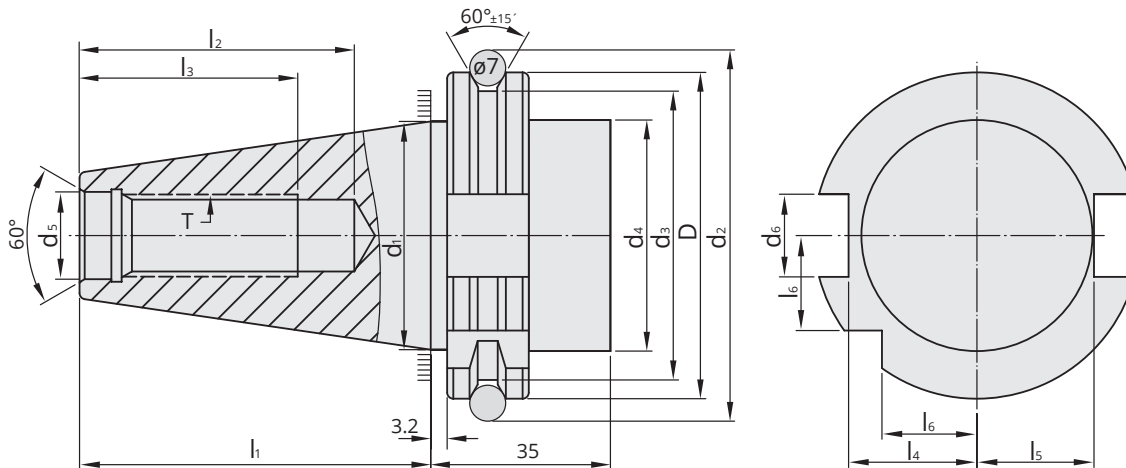

SK	D	d ₁	d ₂	d ₃	d ₄	d ₅	d ₆	d ₉	l ₁	l ₂	l ₃	l ₄	l ₅	l ₆	e ₁	e ₂	T
	⁰ _{-0,1}		±0,05	⁰ _{-0,5}	max	H7	H12		⁰ _{-0,3}	min	min	⁰ _{-0,4}	⁰ _{-0,4}	⁰ _{-0,3}	±0,1	max	
30	50,00	31,75	59,30	44,30	45	13	16,1	4	47,8	33,5	24	19	16,4	15	21	5	M12
40	63,55	44,45	72,30	56,25	50	17	16,1	4	68,4	42,5	32	25	22,8	18,5	27	5	M16
50	97,50	69,85	107,25	91,25	80	25	25,7	6	101,75	61,5	47	37,7	35,5	30	42	7	M24

Vorgewuchtet G 6,3 15.000 min⁻¹
Pre-balanced
 Pré-équilibré

G 2,5 Feinwuchten gegen Aufpreis
G 2.5 Fine balancing at extra charge
 G 2,5 Équilibrage de précision moyennant un supplément

Mit innerer Kühlmittelzufuhr über den Bund - Form AD/AF (ehemals AD/B)

With internal coolant through the collar - form AD/AF (formerly AD/B)
Avec arrosage interne par la collerette - forme AD/AF (anciennement AD/B)

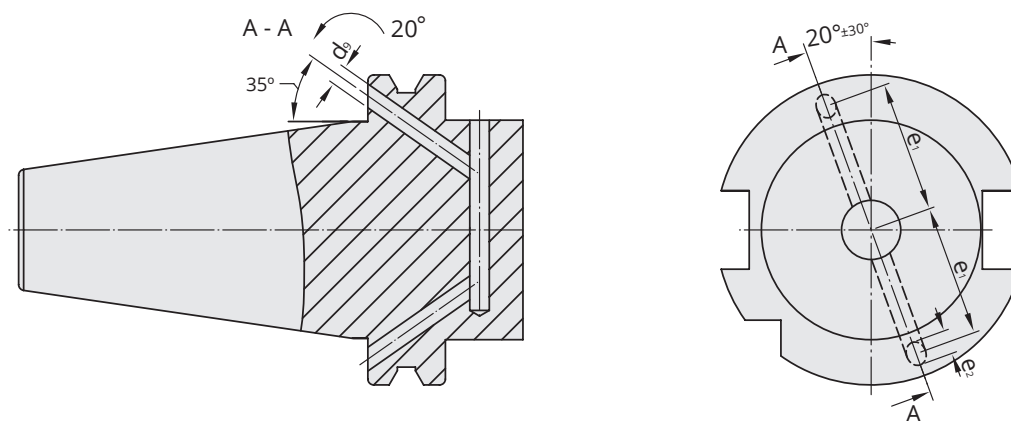

Werkstoff: Legierter Einsatzstahl mit einer Zugfestigkeit im Kern von min. 950 N / mm². Einsatzgehärtet HRC 60 ± 2 (HV 700 ± 50), Härtetiefe 0,8 mm ± 0,2 mm, brüniert und präzisionsgeschliffen.

Form AD/AF: Lieferung in Ausführung AD, Form AF (B) mit lösbaren Gewindestiften verschlossen.

Genauigkeit: Kegelwinkel - Toleranzqualität < AT 3 nach DIN 7187 und DIN 2080.

Material: Alloyed case-hardened steel, tensile core strength of min. 950 N / mm². Case hardened HRC 60 ± 2 (HV 700 ± 50), hardening depth 0.8 mm ± 0.2 mm, black-finished and precisely grinded.

Form AD/AF: Delivery in form AD, type (B) closed with releasable headless screws.

Accuracy: Quality of taper < AT 3 according to DIN 7187 and DIN 2080.

Matière: Acier de cémentation allié. Résistance à la traction dans le noyau d'au moins 950 N / mm². Cémenté et trempé HRC 60 ± 2 (HV 700 ± 50), profondeur de trempé 0,8 mm ± 0,2 mm, brunie et rectifiée avec précision.

Forme AD/AF: Livraison en forme AD, forme AF (B) fermée avec de vis sans tête amovibles.

Précision: Angle de cône - qualité de tolérance < AT 3 selon DIN 7187 et DIN 2080



Example:

40 3 . 02 . 20 . 1

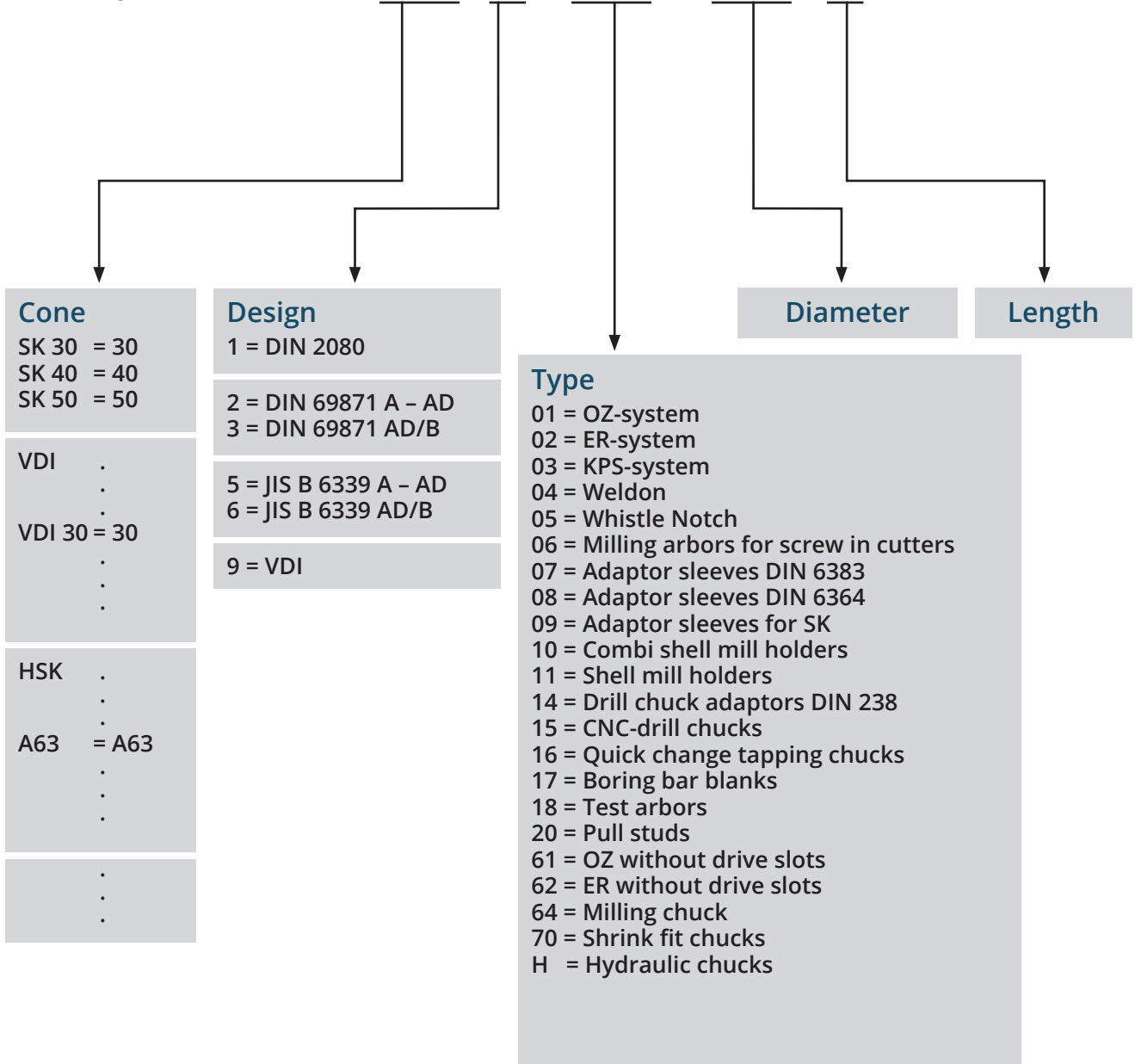



The process of tapping is a complex balance of rotational and axial movements of the tool. It is sometimes necessary to restrict the axial movements of the tool.

If the axial movement is not accurately controlled, the leading or trailing flanks of the tap may be forced to progressively “shave” one flank of the component thread, thus producing a thin and oversize thread in the component.

Tension – forward float capability allows the tap to progress into the component without interference from the axial feed of the machine spindle.

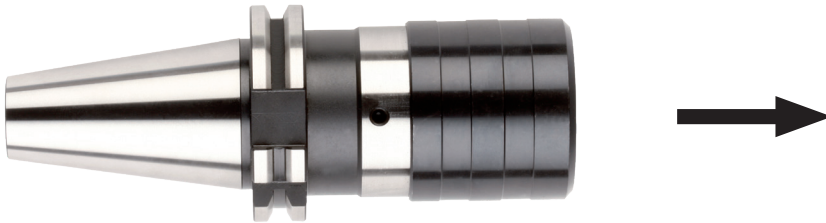

Compression – backward float capability, acts as a cushion and allows the tap to commence cutting at its own axial feed independent of the machine spindle.

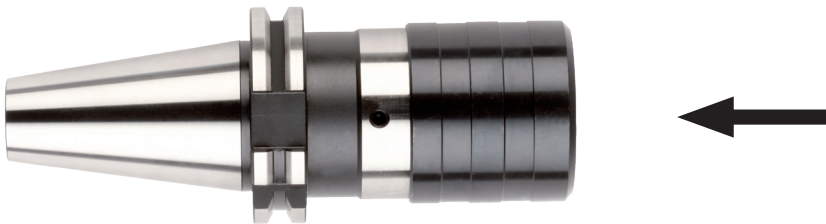

Compression/Tension – float is designed to negate any external forces during the machining operation.



Radial float – allows for slight misalignment of the machine spindle axis and hole axis prior to tapping. This is not recommended manufacturing practice and should be avoided.

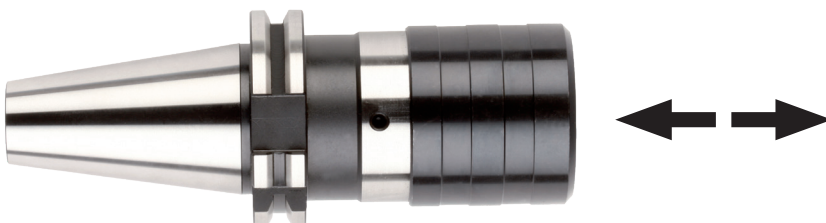



For a correct use of the tapping chuck, please check, during the first thread, not to exceed the max. axial stroke of the compensation values. This is to avoid damaging the thread or the tapping chuck.



Adjustment screw for amplification of chamfer edge pressure. Turning the screw clockwise amplifies the chamfer edge pressure.

Compensation in compression



Compensation in extension

Code	Tap capacity	Adapters	Length adjustment in mm on	
			Compression	Extension
xxx.16.12	M 3 - M14	16.11.xx / 16.01.xx	7	7
xxx.16.20	M 5 - M22	16.12.xx / 16.02.xx	12	12
xxx.16.36	M14 - M36	16.14.xx / 16.03.xx	17.5	17.5