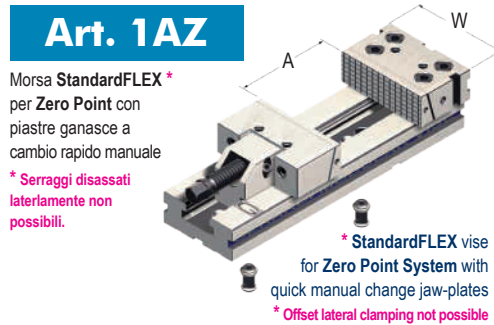

Tipo (grandezza) morsa / Vise type (size)	kN	1*		2		3		4	
		16 kN	25 kN	30 kN		30 kN			
Apertura massima / Maximum spread	A	100	150	200	300	200	300	400	500
<b>Art. 1AZ</b>	W	96	121	146		171			
	B	28	38	48		58			
	C	35	40	50		58			
	D	270	345	420	520	455	555	655	755
	G	75	95	125		145			
	kg	7.3	13.2	26.2	29.7	37.9	43	48.1	53.2
	Cod.	1.1A.Z1000	1.1A.Z2000	1.1A.Z3200	1.1A.Z3300	1.1A.Z4200	1.1A.Z4300	1.1A.Z4400	1.1A.Z4500

**AMPLIA LE TUE APPLICAZIONI TRAMITE GLI ACCESSORI MODULARI !**

Art. 230E	Cod.		4.23.0E101		4.23.0E201		4.23.0E301		4.23.0E401	
	Piastra ganascia intercambiabile Interchangeable jaw plate	H	23	33	43					53
Vedi pagina 4.21 per altezze disponibili See page 4.21 for available height	H1	5	5	5					5	

Art. 212	Cod.		1.21.21000		1.21.22000		1.21.23000		1.21.24000	
	Ganascia mobile intermedia (da usare con Art. 230E) Intermediate movable jaw (to be used with Art. 230E)	[Diagram showing jaw plate with height H]								

Art. 230B	Cod.		4.23.0B101		4.23.0B201		4.23.0B301		4.23.0B401	
	Piastra ganascia intercambiabile dolce Soft interchangeable jaw plate	[Diagram showing jaw plate with 22mm width]								

Art. 230F	Cod.		4.23.0F101		4.23.0F201		4.23.0F301		4.23.0F401	
	Piastra ganascia intercambiabile prismatica Prismatic interchangeable jaw plate	[Diagram showing prismatic jaw plate]								

Art. 1AZE	Cod.		Vedi pag. 4.40 - 4.41 - See pag. 4.40 - 4.41	
	Morsa modulare StandardMatic con cilindro idraulico a SINGOLO effetto	[Diagram showing modular vise]		

**MORSE StandardMatic**

Art. 1AZ - Art. 258 + Art. 271 = Art. 1AZE

StandardMatic precision modular vise with SINGLE effect hydraulic cylinder

CENTRALINA POWER UNIT (EXTRA)

Dotazione standard:

- 1 arresto laterale Art. 370
- 2 tiranti Art. 10A
- 2 tappi Art. 291
- 1 chiave a pipa Art. 375
- 1 chiave a "T" Art. 376

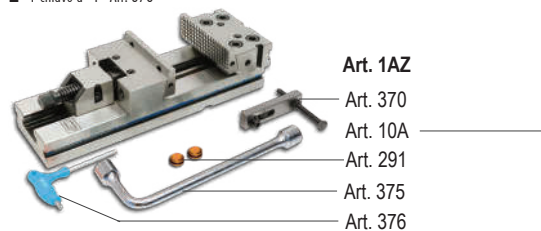

Standard equipment:

- 1 workstop Art. 370
- 2 pullstuds Art. 10A
- 2 inserts Art. 291
- 1 box wrench Art. 375
- 1 T-wrench Art. 376

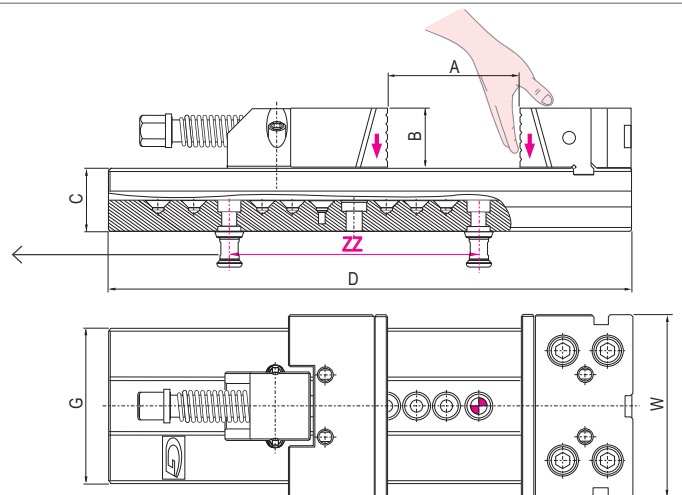

\* Per morsa Tipo 1 sedi per tiranti 10A (tipo1) con interasse dei fori 150mm - Quote interassi tiranti ZZ a pag.1.24

For Vise T.1 - 10A pull studs positioning holes (T.1) with 150mm pitch - See on pag. 1.24 for pull studs pitches ZZ

 Vedi gruppo 4 per gamma completa accessori  
 See group 4 for complete range of accessories

	5 40 kN					6 40 kN						
A	200	300	400	500	600	200	300	400	500	600	700	800
W	196					296						
B	63					78						
C	70					78						
D	495	595	695	795	895	535	635	735	835	935	1035	1135
G	200					300						
kg	65.3	70.3	75.3	80.3	85.3	97	107	117	127	137	147	157
Cod.	1.1A.Z5200	1.1A.Z5300	1.1A.Z5400	1.1A.Z5500	1.1A.Z5600	1.1A.Z6200	1.1A.Z6300	1.1A.Z6400	1.1A.Z6500	1.1A.Z6600	1.1A.Z6700	1.1A.Z6800

**UPGRADE YOUR VISE APPLICATIONS THROUGH MODULAR ACCESSORIES !**

4.23.0E501

**Art. 230E**

H	53
H1	10

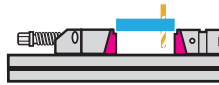

4.23.0E601

68
10

1.21.25000

**Art. 212**

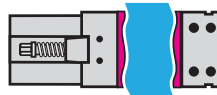

1.21.26000

4.23.0B501

**Art. 230B**

4.23.0B601

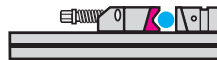
4.23.0F501

**Art. 230F**

4.23.0F601

Cod.

Vedi pag. 4.40 - 4.41 - See pag. 4.40 - 4.41

**StandardMatic VISES**

**Centralina Pneumoidraulica Art.393/394/395 (EXTRA)**  
 Pneumohydraulic Power Unit Art.393/394/395 (EXTRA)

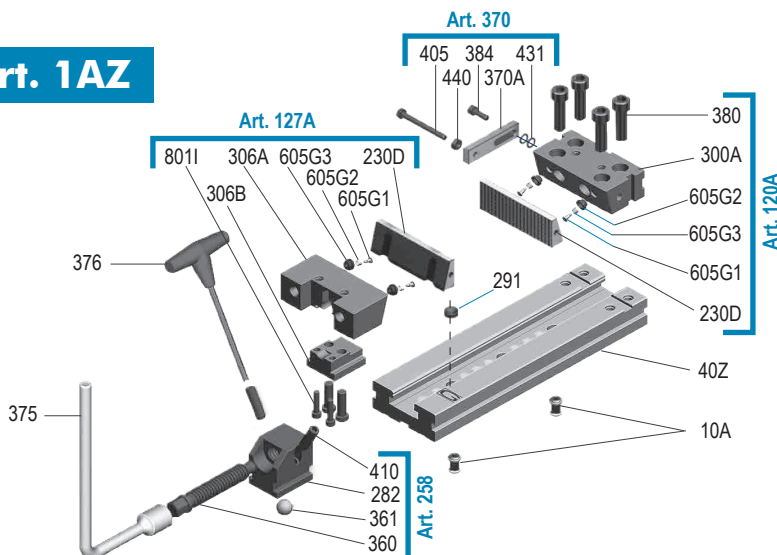
**Art. 1AZ**

Art.	Pag.
<b>10A</b>	9.31
<b>40Z</b>	1.24
<b>230D</b>	4.21
<b>282</b>	4.36
<b>291</b>	4.35
<b>300A</b>	4.30
<b>306A</b>	4.30
<b>306B</b>	4.30
<b>360</b>	4.36
<b>361</b>	4.36
<b>370A</b>	4.35
<b>375</b>	4.35

Art.	Pag.
<b>376</b>	4.35
<b>380</b>	4.28
<b>384</b>	4.28
<b>405</b>	4.35
<b>410</b>	4.36
<b>431</b>	4.28
<b>440</b>	4.28
<b>605G1</b>	4.22
<b>605G2</b>	4.22
<b>605G3</b>	4.22
<b>801I</b>	5.61
-	-

# Morse e Cubi / Vises & Vise Towers

# StandardFLEX

 Precisione / Accuracy  
 $\pm 0,02\text{mm}$ 

 Durezza / Hardened  
**HRC 58 $\pm$ 2**

**La morsa più evoluta!**  
 The most recent vise!

## CARATTERISTICHE & VANTAGGI

- ✓ USURA INESISTENTE
- ✓ RAPIDITA' DEI SERRAGGI
- ✓ MODULARITA' & VERSATILITA'
- ✓ PRECISIONI  $\pm 0,02\text{ mm}$
- ✓ RIGIDITA' & SICUREZZA
- ✓ DESIGN COMPATTO E MANEGGEVOLEZZA

Si rimanda a quanto esposto a pag. 1.4 e 1.5

## TECHNICAL FEATURES & ADVANTAGES

- ✓ NO WEAR
- ✓ QUICK CLAMPING
- ✓ MODULARITY & VERSATILITY
- ✓ HIGHEST ACCURACIES  $\pm 0,02\text{ mm}$
- ✓ RIGIDITY & SAFETY
- ✓ SPACE SAVING DESIGN & HANDY

See pag. 1.4 and 1.5 (STANDARD series vises)

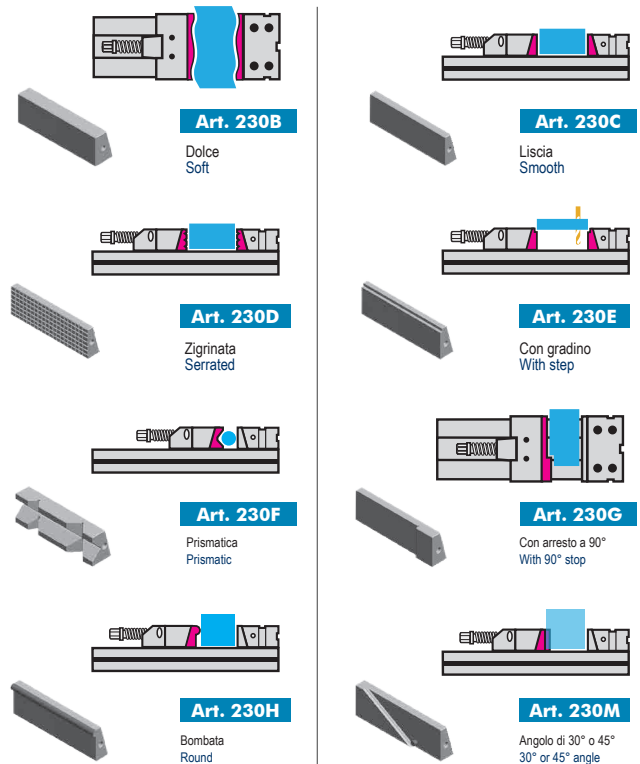

**PIASTRE GANASCE DISCENDENTI INTERCAMBIABILI MANUALMENTE**  
 PULL DOWN JAW PLATES INTERCHANGEABLE BY HAND

## Portapiastre The Rack

Completo di piastre ganasce a cambio rapido a gradino Art.230E  
 Complete of quick change step jaw plates Art.230E

Vedi Pag. 4.22 - See Page.4.22

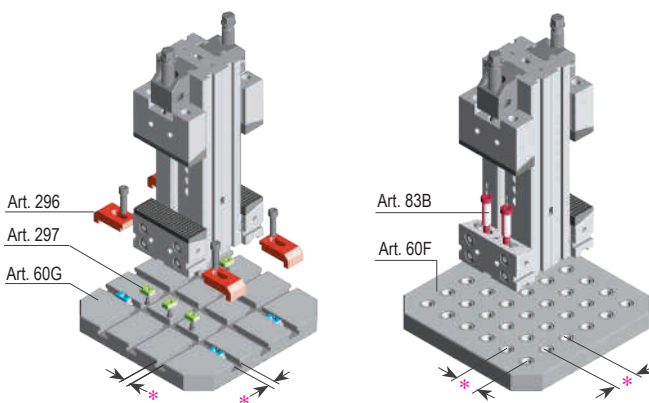
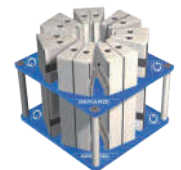

**\* Cava / T slot = 16 mm**  
 Ancoraggio e posizionamento  
 con staffe e chivette  
 Positioning and clamping through vise clamps

**\* Passo / Pitch = 50 mm**  
 Ancoraggio e posizionamento  
 su reticolo  
 Grid clamping and positioning

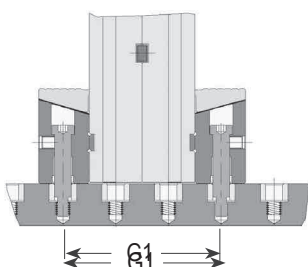

Tipo morsa Vise type	3	4	4	5
G1 mm	150	200	250	

## Coda di Rondine Dove Tail

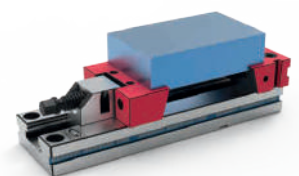

Rimuovendo le piastre ganasce è possibile sfruttare l'inclinazione a 15° del corpo per serrare il particolare, prelavando la faccia inferiore del particolare ottenendo così un sistema ad incastro irreversibile.

By taking off the jaw plates, it is possible to exploit the body inclination of 15° to clamp the workpiece and pre-machine the lower surface thus obtaining an irreversible dovetail system.

Le morse GERARDI della serie Standardflex sono un'evoluzione della morsa Standard. La loro caratteristica principale è la sostituzione rapida delle piastre ganasce che avviene manualmente e senza l'ausilio di alcun utensile, questo è possibile grazie al sistema Perno-molla, che consente un diverso utilizzo della morsa in tempi ridottissimi. Grazie al sistema a Pettine di rigatura prismatica delle piastre ganasce, risulta migliorato anche l'effetto discendente che durante la fase di serraggio, trascina il pezzo contro lo slittone garantendo anche una notevolissima precisione di riposizionamento.

The GERARDI vises of the StandardFLEX series are an evolution of the Standard vise series. Their main characteristic is the quickest jaw plate hand substitution without any tool. This is possible thanks to the new design with pin with spring which increases the standard vise versatility while the prismatic grooves allow a perfect repositioning accuracy (within microns!!!).

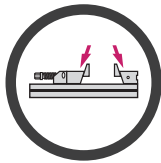

SCAN IT TO WATCH THE



VIDEO PRESENTATION



*Dotata del geniale sistema a pettine per sostituire rapidamente la piastra ganasce discendente*

*Innovative Comb system for quick pull-down jaw plate change*

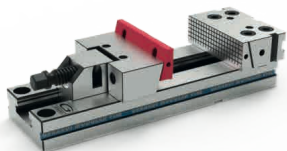

**Riconfigurazione Rapidissima**  
Quickest Vise Resetting

Grazie alla piastra ganasce intercambiabile manualmente tramite sistema a pettine  
Thanks to the quick interchangeable jaw plate through ground comb system

**Altissima Ripetibilità di Posizionamento**  
Highest Repositioning Accuracy  $\pm 0,005\text{mm}$

Veloce e preciso grazie alla forma rettificata del sistema a pettine  
Quick and accurate jaw plate thanks the grid shape of the comb system

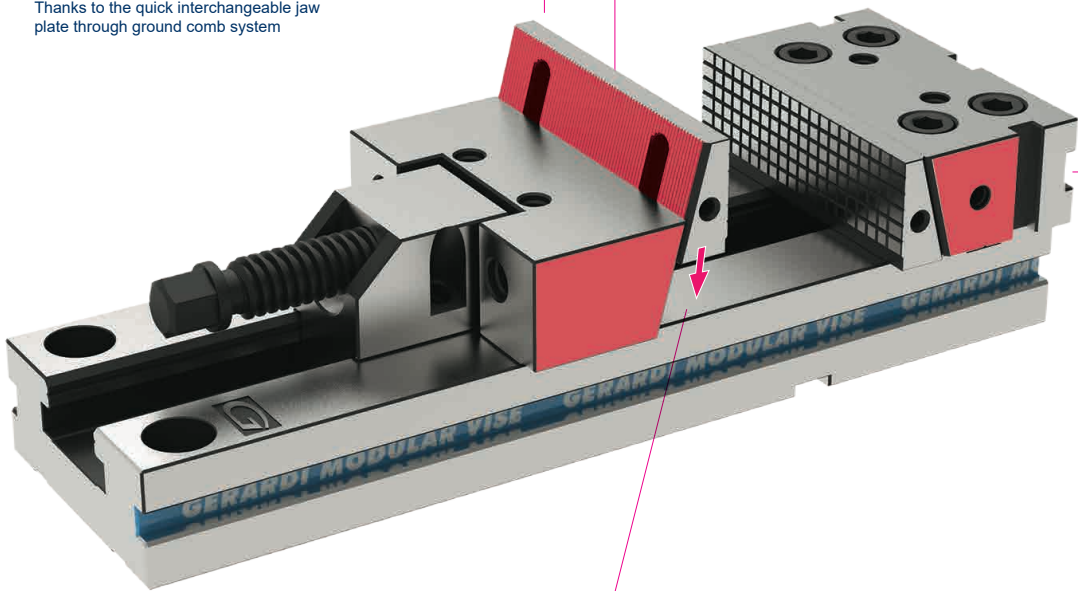

**Effetto discendente**  
Pull Down Action

Effetto discendente amplificato e migliorato e migliore protezione dai trucioli grazie al sistema a pettine.

Increased and better pull down action and better protection from chips thanks to the comb system

**Montaggio Verticale**  
Vertical Mounting

Montaggio in verticale di due morse StandardFlex contrapposte su piani a reticolo  $\varnothing 16\text{mm}$

Example of vertical mounting of 2 StandardFlex vises back to back on grid base  $\varnothing 16 - 50\text{mm Pitch}$

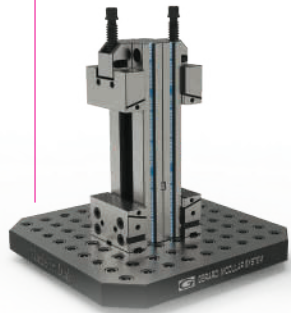

# Staffe d'ancoraggio / Vise holding clamps

**NEW**  
**2024**

## Standard / StandardFLEX

**Coppia staffe di fissaggio Art.296, complete di vite e dado a "T"**
**Pair of vise holding clamps Art.296 complete of screw and "T" nuts**

**Esempio d'ordine per morsa tipo 3 su macchina con cave a T da 18mm: Art.296 T.3 X=18mm**
**Oppure con codice: 2.29.6300 X=18mm**

 Order example for Type 3 vise on machine with 18mm T-slots: Art.296 T.3 X=18mm

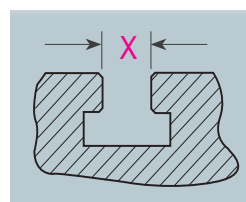
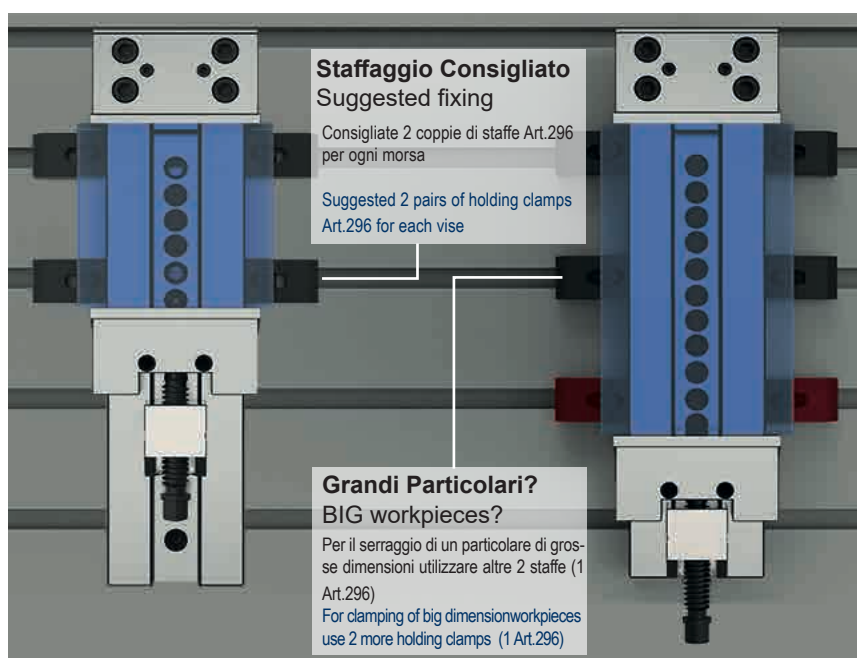
 Also with code: 2.29.6300 X=18mm

**Cava a T**
**T Slot**

Specificare sempre la cava della vostra macchina

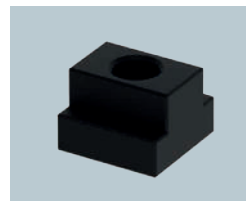
Always specify the machine T-slot dimension

**Art.287 (Pag.4.34)**
**Dadi a T - T Nuts**

Per fissaggio morse alle cave a T della macchina

For vise clamping on the machine T-slots

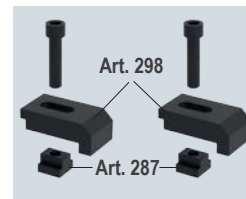
**Art.296**

(Art.298 + Art.287)

Consigliate 2 coppie di staffe Art.296 per ogni morsa

Suggested 2 pairs of holding clamps Art.296 for each vise

Tipo (grandezza) morsa Vise type (size)		1				1 - 2				3 - 4				5 - 6															
<b>Art. 296</b> <b>Coppia di staffe</b> Holding clamps pair	Cava a T slot X	12	14	16	18	12*	14	16	18	20	18*	20	22	16	18	20	22	18*	20	22	16	18	20	22	18*	20	22		
	T-nuts Ref. N°	8	9	10	11	12	13	14	20	21	22	32	33	34	20	21	22	23	32	33	34	20	21	22	23	32	33	34	
	Filetto vite Screw thread	<b>M8</b>				<b>M10</b>				<b>M12 *</b>				<b>M16</b>				<b>M12 *</b>				<b>M16 *</b>							
<b>1 X M8</b> 	A	50	50	50	50	50	50	50	50	76	76	76	76	86	86	86	86	86	86	86	86	86	86	86	86	86	86	86	86
	B	24	24	24	24	24	24	24	24	30	30	30	30	40	40	40	40	40	40	40	40	40	40	40	40	40	40	40	40
	C	6	6	6	6	6	6	6	6	6	6	6	6	10	10	10	10	10	10	10	10	10	10	10	10	10	10	10	10
	Ø D	8,5	11	13	17	11	13	17	17	13	17	17	17	13	17	17	17	13	17	17	17	13	17	17	17	13	17	17	17
	E	10	10	10	10	10	10	10	10	13	13	13	13	15	15	15	15	15	15	15	15	15	15	15	15	15	15	15	15
	Ø F	14	-	-	-	-	-	-	-	-	-	-	-	-	-	-	-	-	-	-	-	-	-	-	-	-	-	-	-
	G	14	16	17,5	19	16	17,5	19	19	17	16	16	16	26	26	26	26	26	26	26	26	26	26	26	26	26	26	26	26
	G1	17	15	13	9	15	13	9	9	22	15	15	15	27	27	27	27	27	27	27	27	27	27	27	27	27	27	27	27
	H	34	34	34	34	34	34	34	34	42	42	42	42	50	50	50	50	50	50	50	50	50	50	50	50	50	50	50	50
	I	8	10	10	10	10	10	10	10	-	-	-	-	-	-	-	-	-	-	-	-	-	-	-	-	-	-	-	-
	J	4	4	4	4	4	4	4	4	10	10	10	10	10	10	10	10	10	10	10	10	10	10	10	10	10	10	10	10
	T ± 0,1	15	15	15	15	15	15	15	15	20	20	20	20	26	26	26	26	26	26	26	26	26	26	26	26	26	26	26	26
	Cod.	2.29.61000 / M8	2.29.61000 / M10	2.29.61000 / M12	2.29.61000 / M16	2.29.63000 / M12	2.29.63000 / M12	2.29.63000 / M12	2.29.65000 / M12	2.29.65000 / M16																			

\* Scelta consigliata - Suggested choice

\* Scelta NON consigliata - NO Suggested choice

## Soluzioni personalizzate / Customized solutions

# Standard / StandardFLEX

Soluzioni personalizzate a tutti i vostri problemi di serraggio

Customized solutions for all your clamping problems

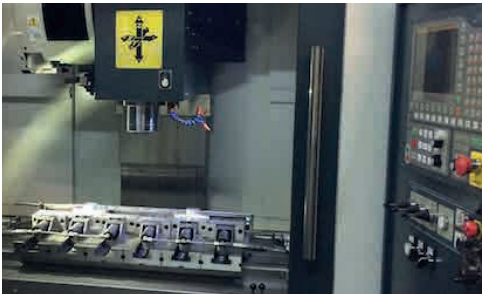

### Morse StandardMatic

StandardMatic vises

**Morse Modulari di Precisione accoppiabili ed allineabili per serraggi multipli Pneumoidraulici (Serie StandardMatic)**

Precision Modular vises matchable for gang operations and Pneumohydraulic clamping (StandardMatic series)



### Modularità & versatilità

Modularity & versatility

**Morsa STD con ganasce lavorabili montata in orizzontale su un centro di lavoro verticale.**

Std vise with machineable jaws horizontally mounted on vertical machining centres.



### Morse modulari di precisione

Precision modular vises

**Morse modulari di precisione allineate per il serraggio di un particolare di grandi dimensioni.**

Precision modular vises aligned for rather big workpiece clamping



### Ganasce monoblocco guidate

Solid Guided jaws

**Ganasce guidate monoblocco costruite con un angolo di spinta verso il basso**

Guided movable jaws built in one solid body with a pull down angle



### Usura inesistente

No wear

**Costruzione in speciali leghe di acciaio ad alta resistenza, normalizzato, cementato e temprato con durezza 60 ±2 HRC**

High alloyed quality resistance steel, case hardened HRC 60±2