

SOVRATAVOLA TONDA / ROUNDED BASE				ACCIAIO - STEEL METAL Fe420			ALLUMINIO / ALUMINUM AL5083			
Dimensioni - Dimensions (mm)				ØA	B	C	Kg	Cod.	Kg	Cod.
Art. 62C Piastra base tonda liscia interfacciata. Piani rettificati Rounded smooth base plate. Faces ground				400	320	38	37	8.62.C4032S	13	8.62.C4032A
				500	400	38	58	8.62.C5040S	21	8.62.C5040A
				630	500	38	93	8.62.C6350S	33	8.62.C6350A
				800	630	38	-	8.62.C8063S	-	8.62.C8063A

Dimensioni - Dimensions (mm)				ØA	B	C	Kg	Cod.	P = 50	Kg	Cod.	P = 50
Art. 62E Piastra base tonda a reticolo interfacciata con fori calibrati e filettati integrali Rounded base plate with solid calibrated holes and threads				400	320	38	37	8.62.E4032S		13	8.62.E4032A	
				500	400	38	58	8.62.E5040S		21	8.62.E5040A	
				630	500	38	93	8.62.E6350S		33	8.62.E6350A	
				800	630	38	150	8.62.E8063S		-	8.62.E8063A	

Tolleranza ± 0,02 mm, □ Interasse reticolo 50mm = Ø 16 / M12 Tolerance ± 0,02 mm, □ Grid pitch 50mm = Ø 16 / M12

Dimensioni - Dimensions (mm)				ØA	B	C	Kg	Cod.	P = 50	Kg	Cod.	P = 50
Art. 62F Piastra base tonda a reticolo interfacciata con bussole di centraggio temprate 100Cr6 e filetti riportati in acciaio inox Grid type pallet rounded base plate with hardened bushings 100Cr6 and inox steel elicoils				400	320	38	-	8.62.F4032S		-	8.61.F4032A	
				500	400	38	-	8.62.F5040S		-	8.62.F5040A	
				630	500	38	-	8.62.F6350S		-	8.62.F6350A	
				800	630	38	-	8.62.F8063S		-	8.62.F8063A	

Tolleranza ± 0,02 mm, □ Interasse reticolo 50mm = Ø 16 / M12 Tolerance ± 0,02 mm, □ Grid pitch 50mm = Ø 16 / M12

Dimensioni - Dimensions (mm)				ØA	C	ACCIAIO - STEEL METAL Fe420		
				ØA	C	Kg	Cod.	
Art. 62G Piastra base tonda interfacciata con cave H7 H7 T-slots round pallet base plate				400	73	-	8.62.G4032S	
				500	73	-	8.62.G5040S	
				630	73	-	8.62.G6350S	
				800	73	-	8.62.G8063S	

In caso di ordine specificare le quote X e Y - Order must include X and Y dimensions

Dimensioni - Dimensions (mm)				ØA	C	ACCIAIO - STEEL METAL Fe420		
				ØA	C	Kg	Cod.	
Art. 62H Piastra base tonda interfacciata con cave H7 H7 T-slots round pallet base plate				400	73	-	8.62.H4032S	
				500	73	-	8.62.H5040S	
				630	73	-	8.62.H6350S	
				800	73	-	8.62.H8063S	

In caso di ordine specificare le quote X e Y - Order must include X and Y dimensions

KIT PIASTRE DI INTERFACCIA TONDE PER TAVOLE ROTANTI

INTERFACED PLATES KIT FOR ROTARY TABLE

NEW
22/23

Dimensioni - Dimensions (mm)				ACCIAIO - STEEL METAL Fe420			ALLUMINIO / ALUMINUM AL5083		
ØA	C	Kg	Cod.	Kg	Cod.				
160	19	-	8.62.K1616S	-	8.62.K1616A				
210	19	-	8.62.K2121S	-	8.62.K2121A				
310	19	-	8.62.K3131S	-	8.62.K3131A				

 * In fase d'ordine specificare costruttore - modello di macchina (fornire disegno) e tipo di morsa
 Specify the manufacturer, the machining center model (send us the drawing) and the type of vise needed when placing the order.

Kit per montaggio e allineamento incluso - Kit for mounting and alignment included

INTERFACCIAMENTO STANDARD

STANDARD INTERFACE

STANDARD EUROPEO
 EUROPEAN STANDARD

A	400	500	630	800
B	-	-	-	-
C	80	100	125	160
B	-	-	-	-

STANDARD GIAPPONESE (Normativa JIS)
 JAPANESE STANDARD (Normative JIS)

A	400	500	630	800
B	55	75	100	135
C	80	100	125	160
B	55	75	100	135

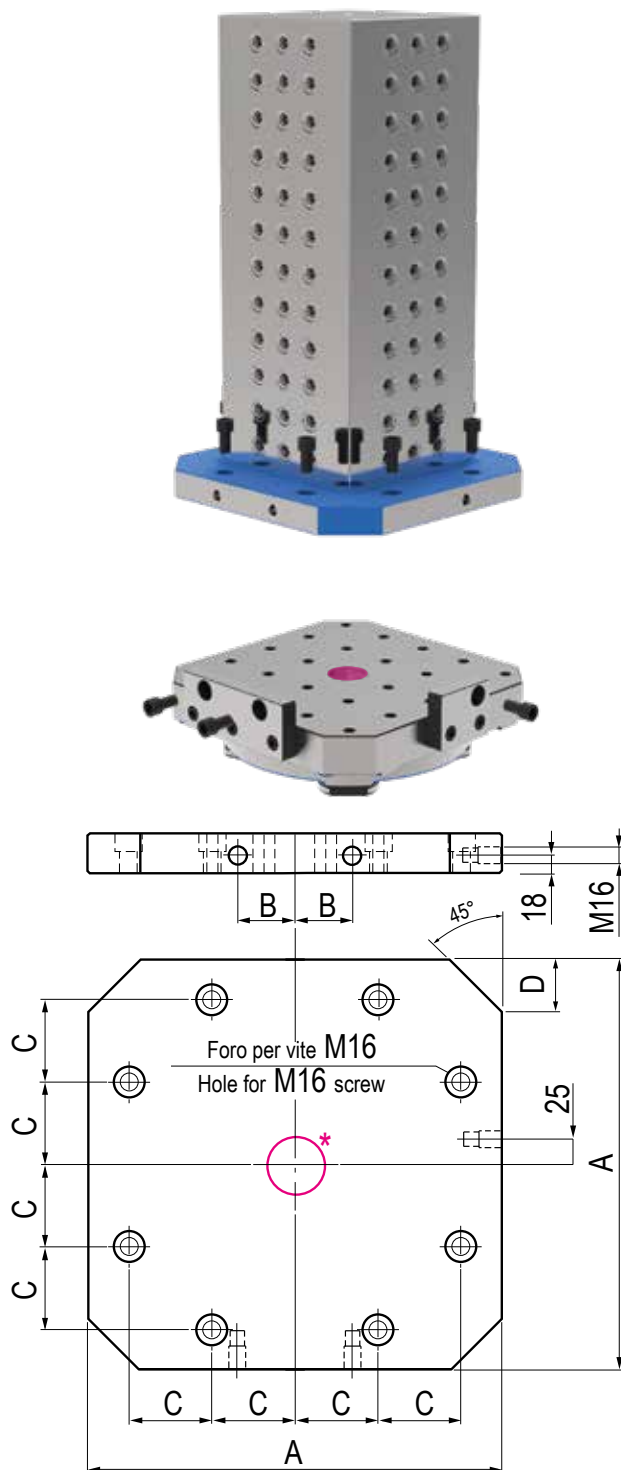
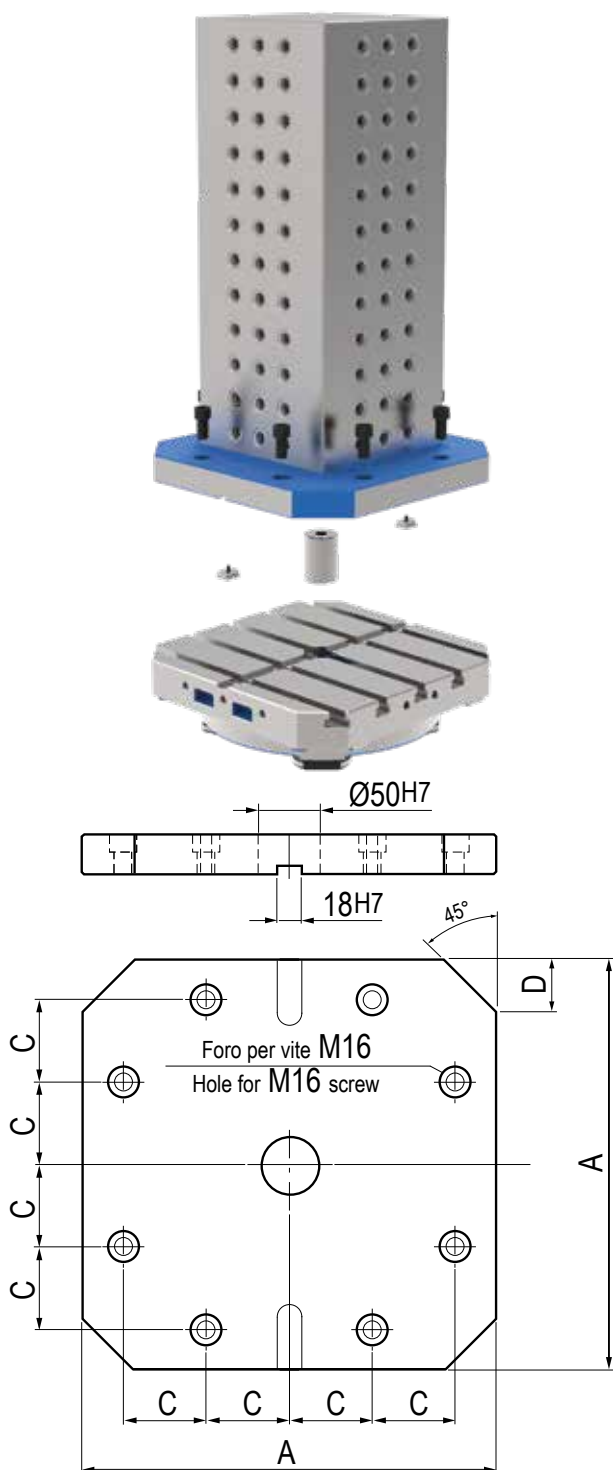

Foro centrale (OPZIONE)* - Central hole (OPTIONAL)*

COME LAVORARE I PORTAPEZZI, TRAMITE ZERO POINT E STAFFE INTELLIGENTI

HOW TO MACHINE TOMBSTONES WITH ZERO POINT AND INTELLIGENT CLAMPS

Tutti i ns. portapezzi (escluso la fusione grezza), sono predisposti, sulla base di appoggio con forature e filettature per l'uso dei tiranti

Zero-Point Art.11A T.2 Questo principalmente significa che tutti i ns. portapezzi possono essere velocemente fissati, posizionati e lavorati sulle 5 facce senza nessun impedimento per quanto riguarda il percorso utensili.

All our tombstone fixture (rough cast iron casting excluded) are pre-worked and prepared on the bottom base face for our Zero-Point pull-stud Art.11A T.2. This important feature will give you many possible application.

Fig.1
Pic.1

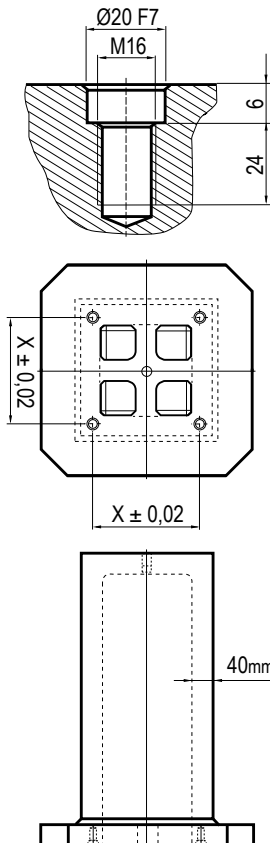

* Sulle superfici grezze aggiungere 5mm
 * Add 5mm on the rough surfaces

Fig.2
Pic.2

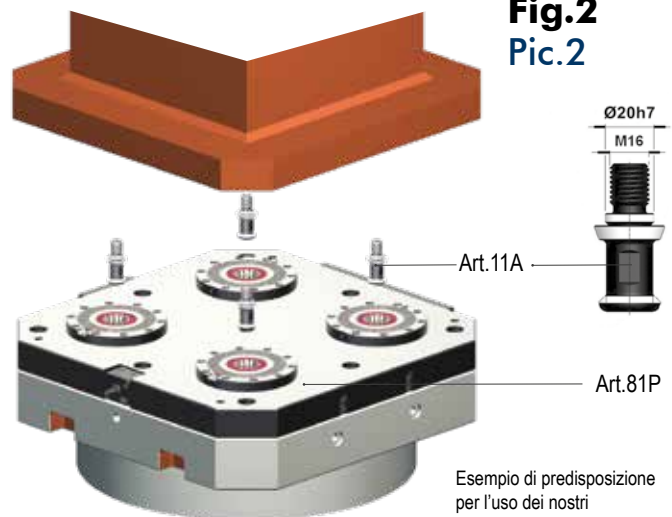

Esempio di predisposizione per l'uso dei nostri "Zero Point System"
 Prearranged work for the use of our "Zero Point System"

Per montaggio, posizionamento e ancoraggio istantaneo con necessità di collegamento pneumatico solo per lo sbloccaggio. Il bloccaggio è meccanico tramite molle. Con questo sistema il pallet può tranquillamente essere movimentato senza l'ausilio di collegamenti elettrici, elettronici, idraulici o pneumatici.

Quick clamping and accurate positioning set up of your tombstone through pneumatic source (only for unclamping - clamping is mechanically maintained by springs)
 With this system your pallet could easily travel without the need of electrical pneumatic or electronic connection.

Fig.3
Pic.3

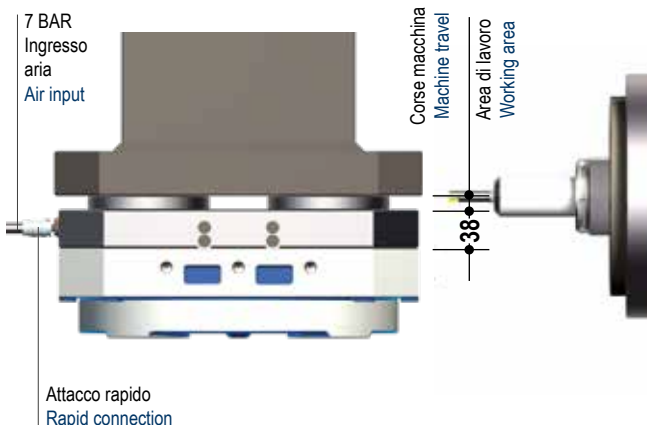

Gli "Zero Point Gerardi" sono utilizzabili anche per ottimizzare le corse del Vs. centro orizzontale sollevando il pezzo all'altezza desiderata senza l'ausilio di sovravole.

Our hydraulic or pneumatic "Zero Point Gerardi" are also used to optimize the vertical travel of your horizontal machining center without the need of extra over pallet plates.

Fig.4
Pic.4

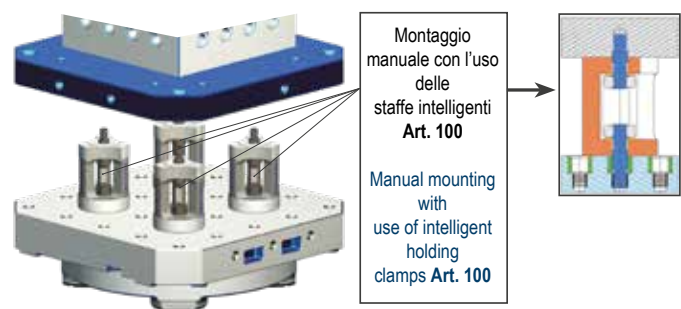

I fori di predisposizione (Fig.1- pag. 8.5) possono essere usati anche per l'utilizzo di "staffe intelligenti" Art.100 e relativi prigionieri.

The pre-work holes (Pic.1- pag. 8.5) are also coming handy for the use of our "intelligent clamps" Art. 100

Montaggio manuale con l'uso delle staffe intelligenti Art. 100
 Manual mounting with use of intelligent holding clamps Art. 100

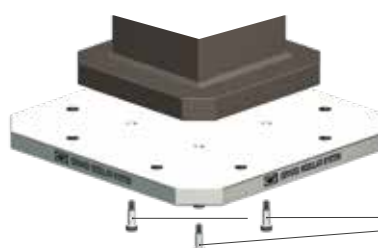

Inoltre con questo sistema di predisposizione potete fissare una piastra che vi permette l'interfacciamento sulla Vs. macchina o attrezzatura. (Fig.1)

Further more with this solution you can fix any plate you wish to adapt as you need (Pic.1)

Art. 100



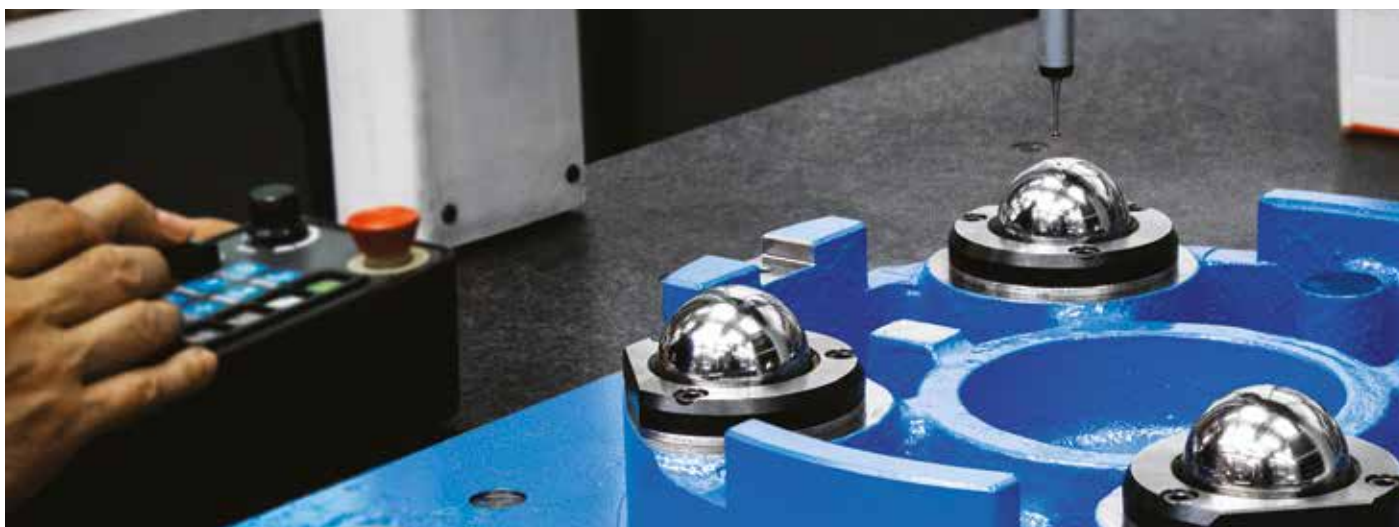

VERIFICHE DIMENSIONALI TRAMITE MACCHINE DI MISURA

DIMENSIONAL CHECK THROUGH MEASUREMENT MACHINES

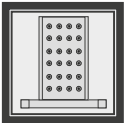
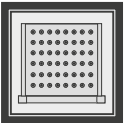

SIMBOLOGIA DATI TECNICI

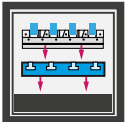
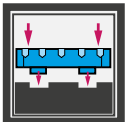
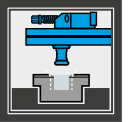
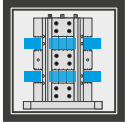
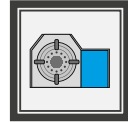
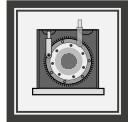
TECHNICAL DATA ICONS

MODELLI PORTAPEZZI TOMBSTONE MODELS			 Cubi Cubes	 Spalle 2 Sides tombstones	 Cubi a croce Cross cubes	 Squadre Angles
PIASTRE E PALLET PLATES AND PALLET					 Piastre e sovravole Plates & Interfaced plates	 Pallet macchina Machine pallet
POSSIBILITÀ DI POSSIBILITY OF			 Posizionamento & cambio rapido Quick change & positioning	 Cubi-morsa Vise tower	 Divisore Automatico Automatic dividing head	 Divisore Meccanico Mechanical dividing head
PAGINE PAGES					 Accessori & Ricambi Accessories & Spare Parts	 Istruzioni corretto utilizzo Instruction for a proper use