

MODELLI DI TORNO COMPATIBILI
 COMPATIBLE LATHE TYPES

VDI 20 / VDI 30 / VDI 40 / VDI 50 / VDI 60

Vedi pagine compatibilità 5.10 / 5.11 - See compatibility pages 5.10 / 5.11

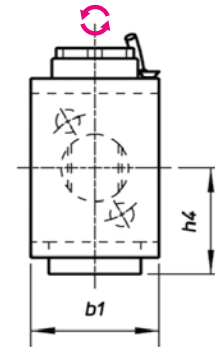
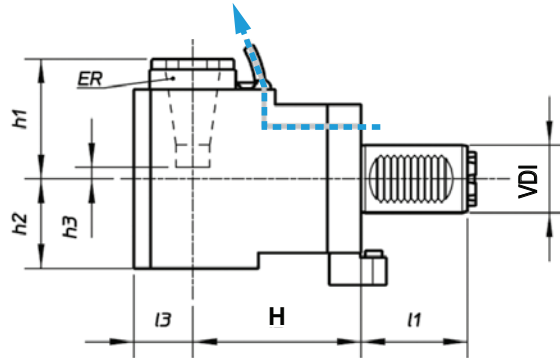

Per dischi radiali - For radial tool discs

 TIPO - TYPE
Radiale
 Radial

 USCITA - OUTPUT
Porta Pinza
 Collet Chuck

 REFRIGERANTE
 COOLANT
Esterno
 External

 RATIO
1:1

 ROTAZIONE - ROTATION
Opposto al mandrino
 Opposite to machine spindle

Code	VDI	Output	Int Cool.	I1	H	I3	b1	h1	h2	h3	h4	Nm	Rpm	kw
99.BF.0057	30	ER-25 - Ø1+16	NO	53	55	31	64	56	48	3	53	32	6000	8
99.BF.0058	30	ER-25 - Ø1+16	NO	53	85	31	64	56	48	3	53	32	6000	8
99.BF.0059	30	ER-25 - Ø1+16	NO	53	100	31	64	56	48	3	53	32	6000	8
99.BF.0060	50	ER-40 - Ø3+30	NO	70	110	44	88	92	73	16	68	100	4000	12

4

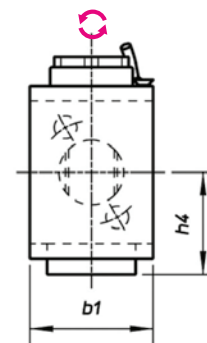
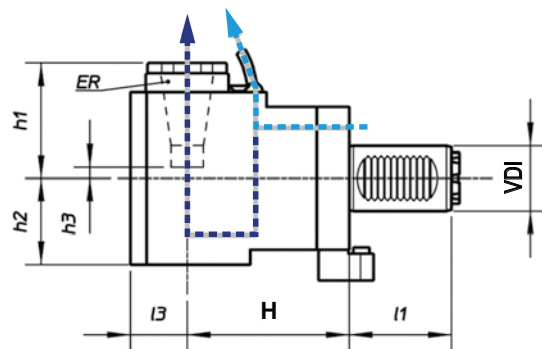

Per dischi radiali - For radial tool discs

 TIPO - TYPE
Radiale
 Radial

 USCITA - OUTPUT
Porta Pinza
 Collet Chuck

 REFRIGERANTE
 COOLANT
25 BAR

 RATIO
1:1

 ROTAZIONE - ROTATION
Opposto al mandrino
 Opposite to machine spindle

Code	VDI	Output	Int Cool.	I1	H	I3	b1	h1	h2	h3	h4	Nm	Rpm	kw
99.BF.0061	30	ER-25 - Ø1+16	✓	53	55	31	64	56	60	3	53	32	6000	8
99.BF.0062	30	ER-25 - Ø1+16	✓	53	85	31	64	56	60	3	53	32	6000	8
99.BF.0063	30	ER-25 - Ø1+16	✓	53	100	31	64	56	60	3	53	32	6000	8
99.BF.0064	50	ER-40 - Ø3+30	✓	70	110	44	88	92	62	16	68	100	4000	12

**TORRETTA TIPO / TURRET TYPE
DIN69880 (VDI STANDARD)**



BARUFFALDI



DIN 5480

DIN 5482

DIN 1809

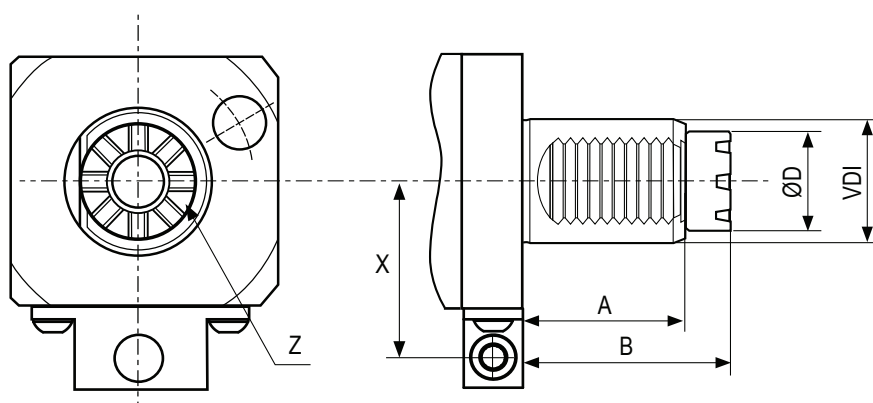

VDI	A	B	ØD	Z (N° denti - Teeth)	X
20	35	44	19	6	50
30	45	59	24	6	40
40	53	68	32	8	63
50	70	84	40	8	70
60	83	100	43	8	-



**DOTAZIONE STANDARD
STANDARD EQUIPMENT**

Chiave bloccaggio albero Art.179CH /
ugello refrigerazione Art.180 / vite bloccaggio ugello
Art.179CH shaft lock wrench /
cooling nozzle Art.180 / nozzle lock screws









CAMBI RAPIDI MODULARI Vedi pag. 7.12 - 7.15
MODULAR QUICK CHANGE See page 7.12 - 7.15

Facile e veloce sistema modulare per il cambio rapido delle diverse
tipologie di portautensili con la sede per pinza ER (DIN6499).
Modular toolholder system for the fitting of toolholders in
a spindle unit with ER collets (DIN6499) outputs.

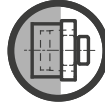
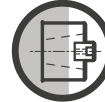
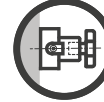
SIMBOLI TIPOLOGIE MOTORIZZATI DRIVEN TOOLS DESIGN LOGOS

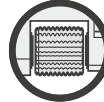
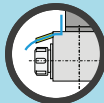
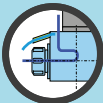
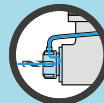
							
Assiale Axial	Assiale doppio Double Axial	Disassato Offset Axis	Disassato Doppio Double Offset Axis	Radiale Radial	Radiale Doppio Double Radial	Radiale 4 Uscite Radial 4 Outputs	Radiale 8 Uscite Radial 8 Outputs
							
Radiale Rovesciato Radial Upside Down	Arretrato Rear Offset	Arretrato Doppio Double Rear Offset	Orientabile ±90° Adjustable ±90°	Portacreatore Driven Gear Hobber			

SIMBOLOGIA DATI TECNICI TECHNICAL DATA LOGOS

USCITA OUTPUT						
	Uscita HSK HSK output	Uscita ISO ISO output	Uscita portafresa Shell mill holder output	Uscita WELDON WELDON output	Uscita CAPTO CAPTO output	Portacreatore Driven Gear Hobber
PASSAGGIO REFRIGERANTE COOLANT						
				Refrigerante Esterno External Coolant	Refrigerante Interno Internal Coolant	Refrigerante Interno Internal Coolant
					20/25/80 100bar	ReCool NUT
USCITA OUTPUT						
			Rapporto Ratio	Rotazione uguale al mandrino Rotation same as machine spindle	Rotazione opposta al mandrino Rotation opposite as machine spindle	Rotaz. uguale ed opposta al mandrino Rotation same & opposite as machine spindle

Portautensili Motorizzati / Driven Tools

VDI



Velocità / High-speed
Max 24.000 Rpm



Internal coolant
fino a / Up to
100 Bar

Portautensili Motorizzati per torni CNC

Driven Tools for CNC lathes

USCITE MULTIPLE

MULTIPLE OUTPUTS

Tutti i motorizzati, ad esclusione di quelli ad angolo variabile, possono essere forniti con doppia pinza contrapposta anche di pari grandezza. Sono stati realizzati per i modelli di tornio più recenti anche motorizzati assiali con doppia / tripla uscita frontale e radiali doppia uscita frontale.

All the driven tools, with the exception of those with adjustable angle, can be supplied with double or multiple output even of the same dimension. Multiple outputs can be opposite or with the same direction.

ALTA VELOCITÀ RATIO 1:4

HIGH SPEED RATIO 1:4

(Opzione di moltiplica del numero di giri dalla torretta del tornio da 2 a 4 volte). Su richiesta, quasi tutti i modelli di motorizzati sono fornibili con velocità di rotazione fino a 24.000 Rpm. Questa soluzione permette di adeguare il numero di giri della torretta alle velocità di taglio delle nuove tipologie di utensili in commercio. Il sistema epicicloidale (interno) consente di mantenere inalterate le dimensioni di ingombro dei vari modelli, senza quindi penalizzare in alcun modo la funzionalità della macchina.

N.B: I MOTORIZZATI STANDARD CON RAPPORTO 1:1 HANNO REGIME DI ROTAZIONE MAX. 6.000 RPM.

All the driven tools types are available with speed until 24.000 Rpm. There is also the possibility of speed increaser from 2 to 4 times thus adapting the Rpm of the turret drive to the speed of today's cutting tools. The epicyclic speed increaser system (a system of satellite gears) is self contained in the standard head overall dimensions and guarantees the same standards of quality and reliability.

ATTENTION: THE STANDARD ROTARY TOOLS WITH 1:1 RATIO HAVE A MAX SPEED OF 6.000 Rpm

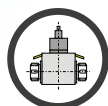

Radiale Doppio
Double Radial

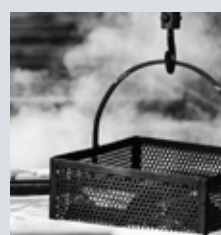

Trattamento Corpo

Main body Treated

Trattamento protettivo anti-ossidante del corpo

Specially treated corrosion resistant steel body

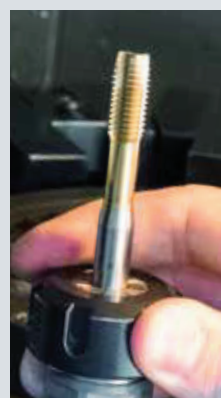

Maschiatura

Tapping

Per le operazioni di maschiatura, tutti i nostri motorizzati possono utilizzare pinze compensate ET-1 perfettamente intercambiabili con le normali pinze secondo norma DIN 6499. Esse consentono una compensazione assiale da 7 a 13 mm a seconda della grandezza per recuperare eventuali errori di avanzamento e per l'inversione della rotazione.

For tapping operations all driven tools can be equipped with axially compensated collets ET-1 interchangeable with the standard ER collets according to the international standard DIN 6499. They allow the tap on axial compensation from 7 to 13 mm according to their size in order to compensate any feed error and the inversion of the rotation of direction.



Cuscinetti

Ball Bearings

Cuscinetti di precisione a contatto obliquo, precaricati e lubrificati con grasso a vita.

Preloaded angular contact ball bearings precision and long life lubrication.



Ingranaggi Gleason

Gleason Spiral bevel gears

Coppia conica di ingranaggi spirroidali Gleason con evolvente rettificato ottimizzato

Gleason spiral bevel gears with completely ground involute form

I portautensili motorizzati per centri di tornitura a controllo numerico consentono di eseguire lavorazioni di fresatura, foratura e maschiatura sul tornio stesso e senza ulteriori piazzamenti. Anche in questo caso Gerardi propone un'ampia gamma di modelli, adatti ad attrezzare i torni e le torrette motorizzate dei maggiori costruttori di torni a livello mondiale con un rapporto qualità/prezzo insuperabile.

Driven tools for CNC turning centres allows milling, drilling and tapping operations on the lathes without additional parts handling. Also in this case Gerardi can supply a wide range of types in order to equip the CNC lathes and turrets of the most popular builders on the market with an unbeatable price/quality ratio.

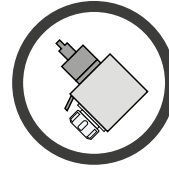

SCAN THE QR CODE



AND FIND OUT MORE



Scegli il modello più adatto alla tua lavorazione!

Choose the right model to have the best machining!



Refrigerante Interno
Internal Coolant

Tutti i motorizzati possono essere forniti con passaggio refrigerante attraverso l'albero utensile fino a 100bar.

All the driven tools, can be supplied with coolant feed through the spindle with rotating distributor upto 100 bar.

Corpo portautensili a sezione maggiorata per garantire maggior rigidità e minor vibrazioni
Re-designed main body to improve rigidity and reduce vibration.



Refrigerante esterno
10 BAR standard
External Coolant
10 BAR standard

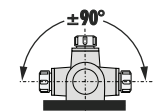

TORRETTE UNIFICATE VDI:
VDI LATHES TURRETS:

DIN 5480



DIN 5482



BARUFFALDI



DIN 1809



DENOMINAZIONE UTENSILE TOOL DESIGNATION

Montaggio TANGENZIALE - OD Mounting

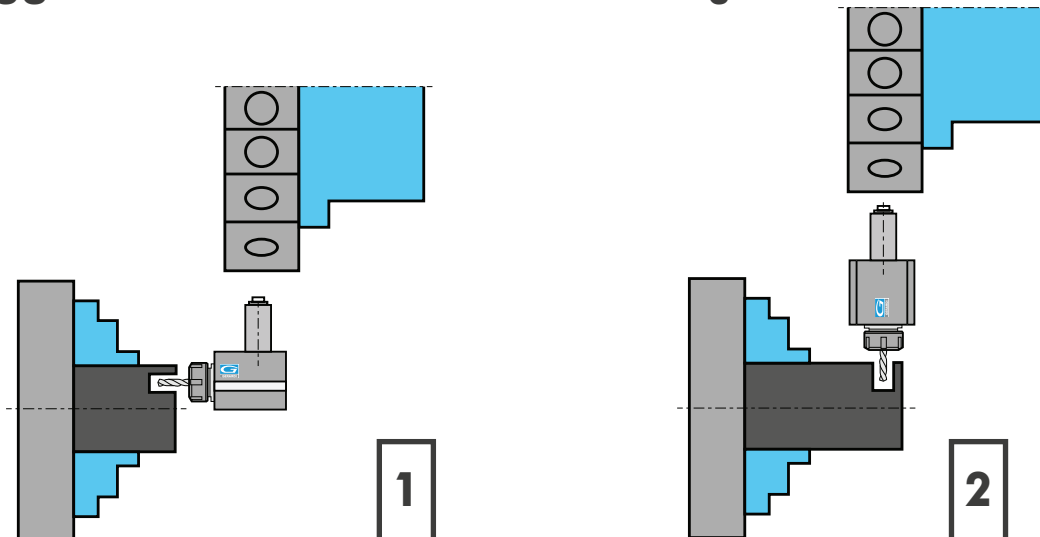

1 Motorizzato **RADIALE** per lavorazioni assiali
RADIAL driven tool for axial machining

2 Motorizzato **ASSIALE** per lavorazioni radiali
AXIAL driven tool heads for radial machining

Montaggio FRONTALE - FACE Mounting

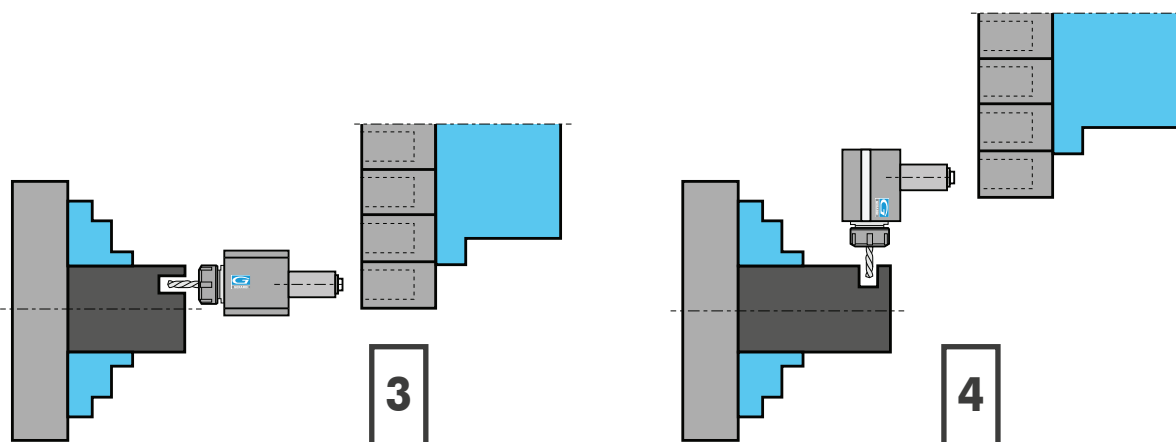

3 Motorizzato **ASSIALE** per lavorazioni assiali
AXIAL driven tool for axial machining

4 Motorizzato **RADIALE** per lavorazioni radiali
RADIAL driven tool heads for radial machining

MOTORIZZATI RADIALI PER LAVORAZIONI ASSIALI

RADIAL DRIVEN TOOLS FOR AXIAL MACHINING

Montaggio TANGENZIALE - OD Mounting

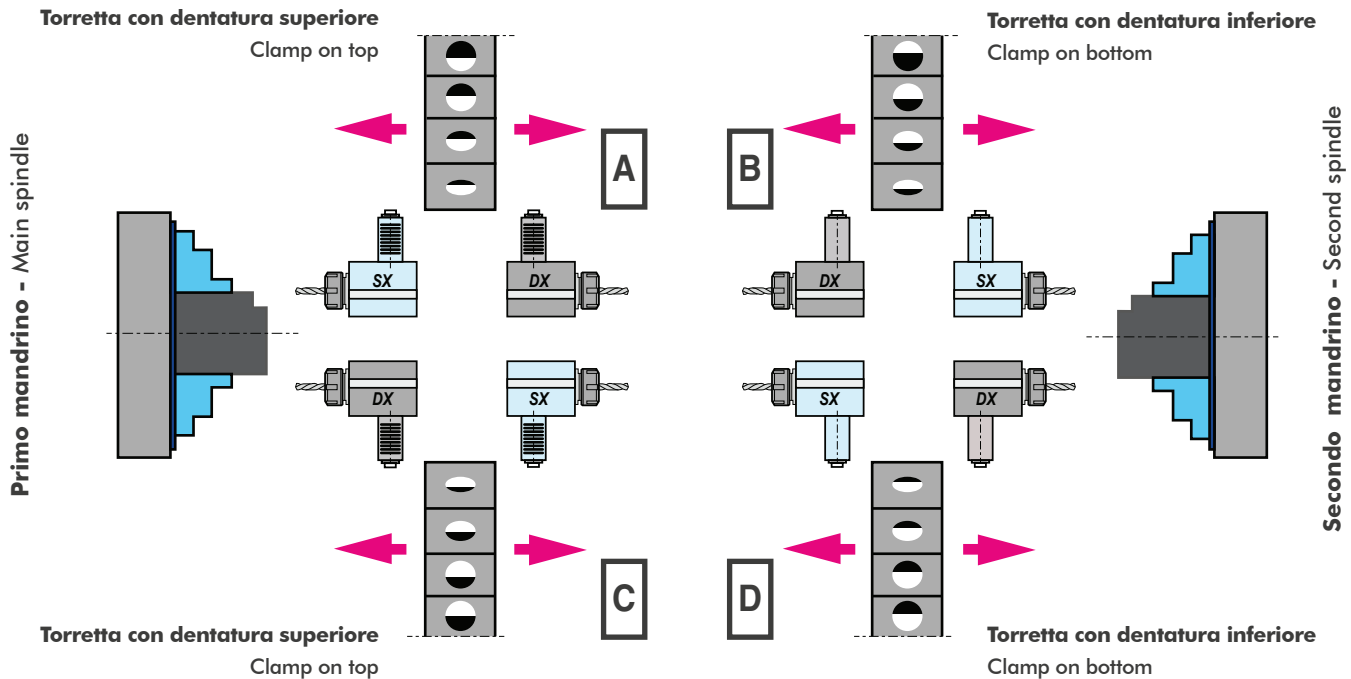

MOTORIZZATI RADIALI PER LAVORAZIONI RADIALI

RADIAL DRIVEN TOOLS FOR RADIAL MACHINING

Montaggio FRONTALE - FACE Mounting

