

External Toolholders

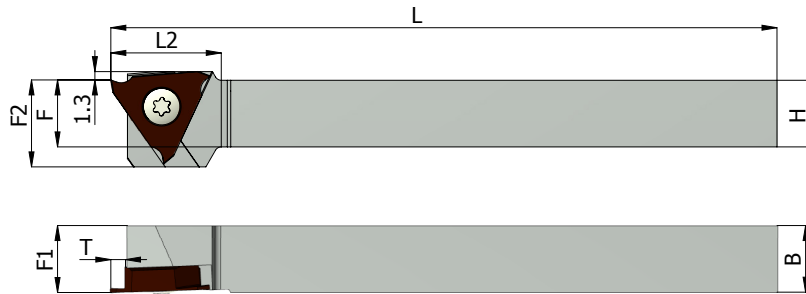

Right Version

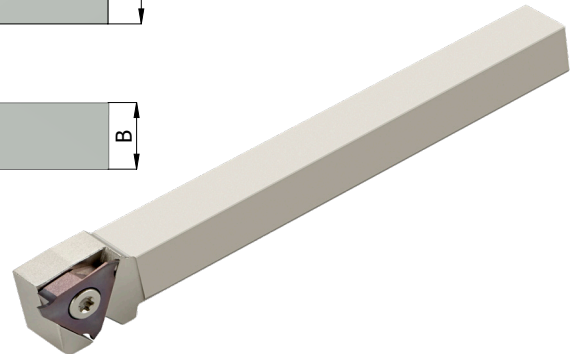

Right hand cutting

Ordering Code	B	H	T	L2	L	F	F1	F2	Insert Screw Torx+	Key Torx+
VGER 0810 K	10	8	2.6	17	125	8	10	13	S16PS	K16P
VGER 1010 K	10	10	2.6	17	125	10	10	13	S16PS	K16P
VGER 1212 K	12	12	2.6	17	125	12	12	13	S16P	K16P
VGER 1616 K	16	16	2.6	17	125	16	16	16	S16P	K16P

For L.H, specify VGE L instead of VGE R

External Toolholders

Product Identification - Ordering Codes

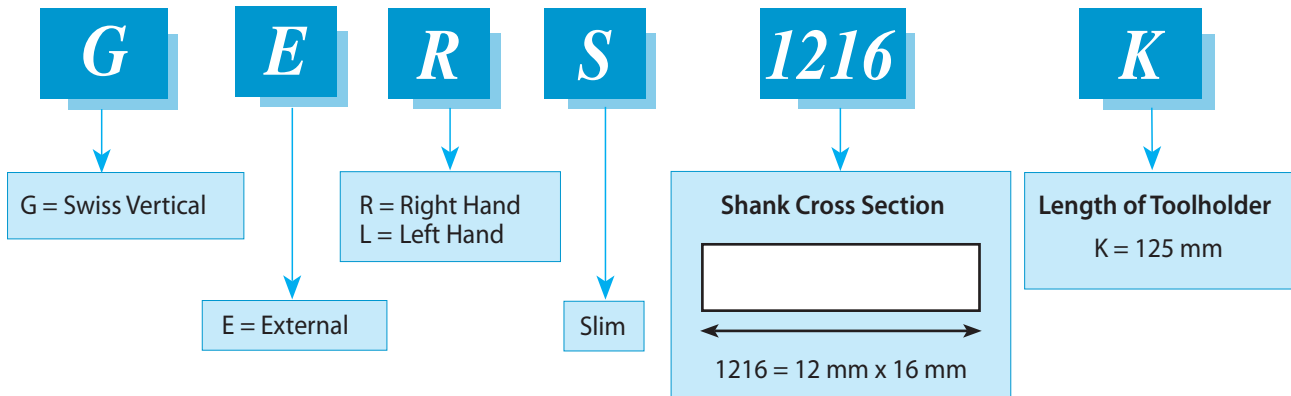

- Coolant through toolholders, for external turning in Swiss type lathes machines.
- The high pressure coolant is directed towards the insert cutting edge, in order to evacuate the chips created and avoid build up edge.
- Includes a coolant connector for fast attachment on the machine.

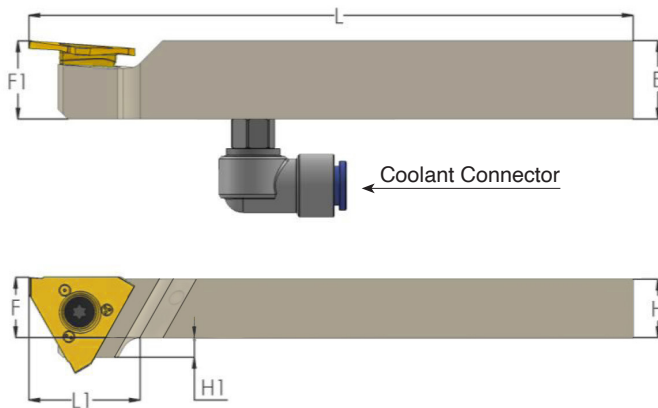

Right Version



Right hand cutting

Ordering Code	B	H	L1	L	F	F1	H1	Insert Screw	Torx Key	*Coolant connector
**GER 0816 K	16	8	17	125	8	16	8	S21	K21	-
GER 1016 K	16	10	17	125	10	16	6	S21	K21	Ø4 / Ø6
GER 1216 K	16	12	17	125	12	16	4	S21	K21	Ø4 / Ø6
GER 1616 K	16	16	-	125	16	16	0	S21	K21	Ø4 / Ø6
GER 2020 K	20	20	-	125	20	20	0	S21	K21	Ø4 / Ø6
GER 2525 M	25	25	-	150	25	25	0	S21	K21	Ø4 / Ø6

For L.H, specify GE L instead of GE R

* Coolant pipe diameter

** Without coolant