

Ordering Code	Insert Type	Insert size A	D	D1	L	No. of Inserts	Screw	Key
SRH40-4	H40	37	40	32	180	4	S45S	K40
SRH45-6	H45	37	45	32	130	6	S45	K40

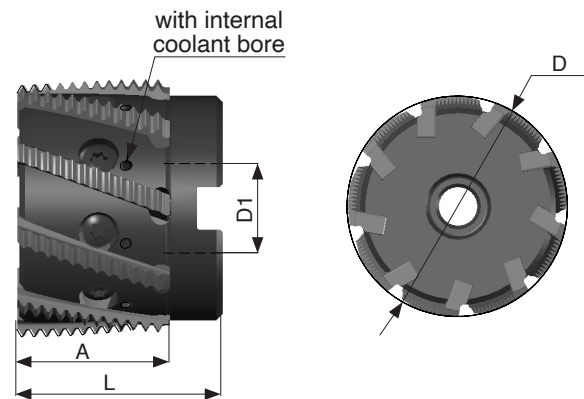

Ordering Code	Insert Type	Insert size A	D	D1	L	No. of Inserts	Screw	Key
SRH32-5M	H32	32	32	16	52	5	S32S	K22
SRH45-6M	H45	37	45	22	60	6	S45S	K40
SRH63-9	H63	38	63	22	50	9	S63	K40

Product Identification - Ordering Codes

Spiral Mill - Thread Inserts

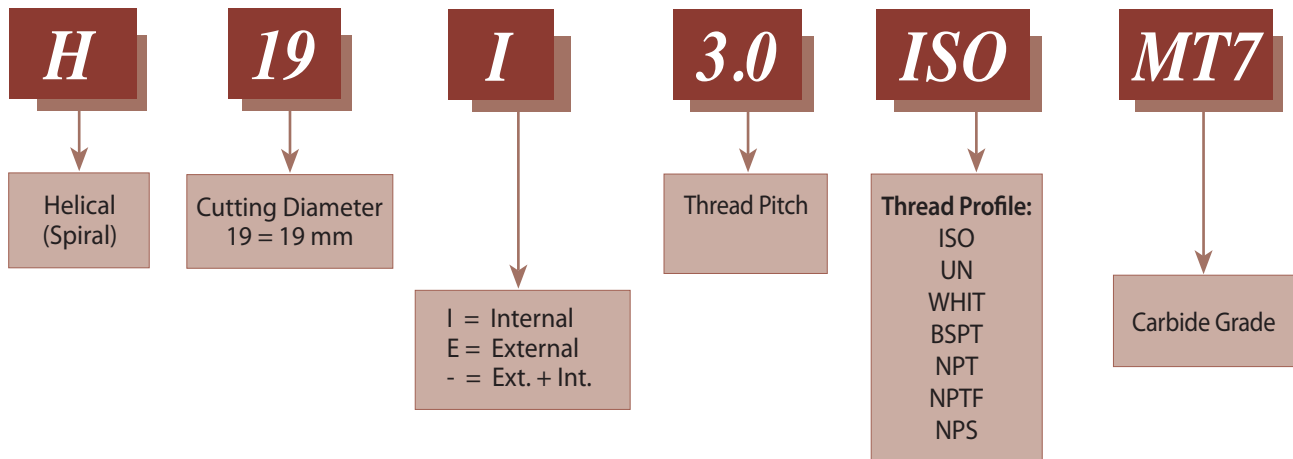

Spiral Mill - Thread Toolholders

