

Toolholders

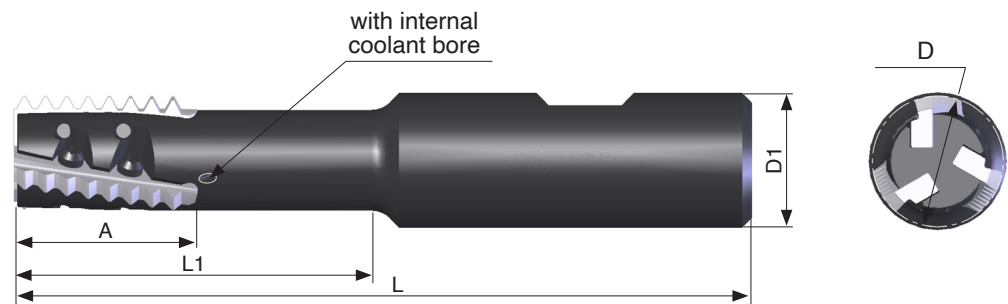

Ordering Code	Insert Type	Insert size A	D	D1	L	L1	No. of Inserts	Screw	Key
SRH13S-1	H13	27	13	20	80	26	1	S13	K11
SRH13-1	H13	27	13	20	90	35	1	S13	K11
SRH15-1	H15	27	15	20	95	40	1	S15	K11
* SRH17-2	H17	27	17	20	85	30	2	S17	K11
* SRH17J-2	H17	27	17	20	100	45	2	S17	K11
SRH19-2	H19	27	19	20	85	30	2	S19	K11
SRH19J-2	H19	27	19	20	110	55	2	S19	K11
SRH19-3	H19	27	19	20	85	30	3	S19	K11
SRH19J-3	H19	27	19	20	110	55	3	S19	K11

* When using NPT, NPTF, BSPT inserts the cutting diameter D = 18 mm

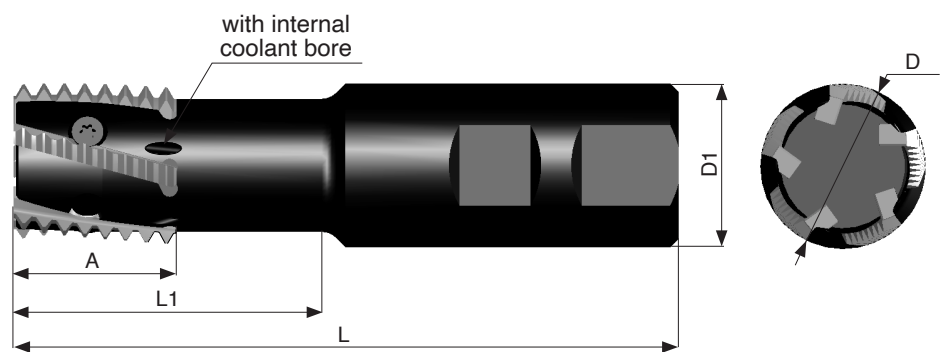

Ordering Code	Insert Type	Insert size A	D	D1	L	L1	No. of Inserts	Screw	Key
SRH23-2	H23	27	23	25	110	50	2	S23	K21
SRH23M-2	H23	27	23	25	150	75	2	S23	K21
SRH28-3	H28	32	28	32	150	75	3	S32S	K22
SRH32-5	H32	32	32	32	130	60	5	S32	K22
SRH32P-5	H32	32	32	32	180	90	5	S32	K22

Product Identification - Ordering Codes

Spiral Mill - Thread Inserts

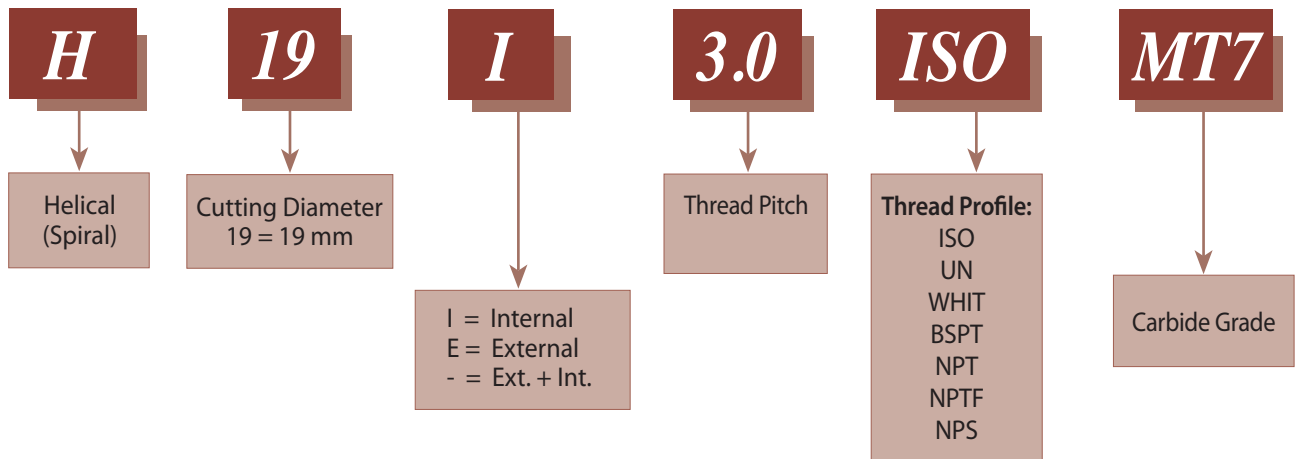

Spiral Mill - Thread Toolholders

