

## Carbide Shank Toolholders

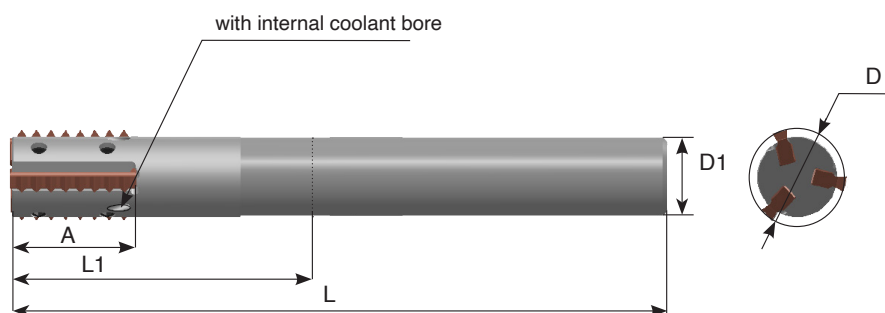

Ordering Code	Insert size=A	D	D1	L	L1	No. of Inserts	Screw	Key
SR 19-70-SL26-2 C	SL 26	19.0	16.0	135	70	2	S4P	K08P
SR 20-70-SL26-3 C		20.5	16.0	135	70	3	S4P	K08P

## Multi-Insert Toolholders

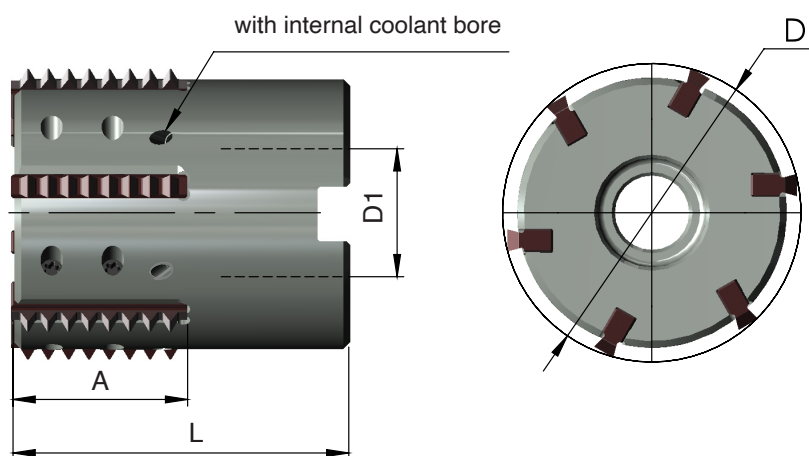

Ordering Code	Insert size=A	D	D1	L	No. of Inserts	Screw	Key
SR 36-16-SL26-5	SL 26	36.0	16	50	5	S4P	K08P
SR 44-22-SL26-6		44.0	22	50	6	S4P	K08P
SR 44-22-SL40-6	SL 40	44.0	22	65	6	S4P	K08P

## ***Slim MT***

### ***High productivity, Slim cost***

A new product line of indexable Mill-Thread inserts and toolholders including multiple straight flutes for machining long threads from small to large diameters.

- **Advanced carbide and coating combination for extended tool life and improved productivity**
- **Most inserts are double sided**
- **Nickel coated holders for high wear resistance**
- **Unique clamping mechanism**
- **Large variety of holders & inserts in accordance to international standards**

## Product Identification

### Inserts

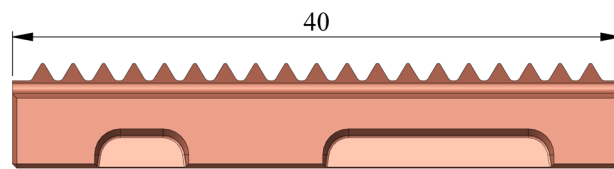
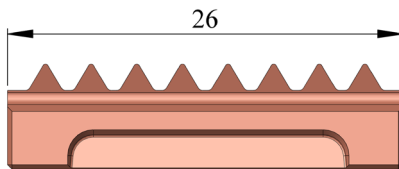
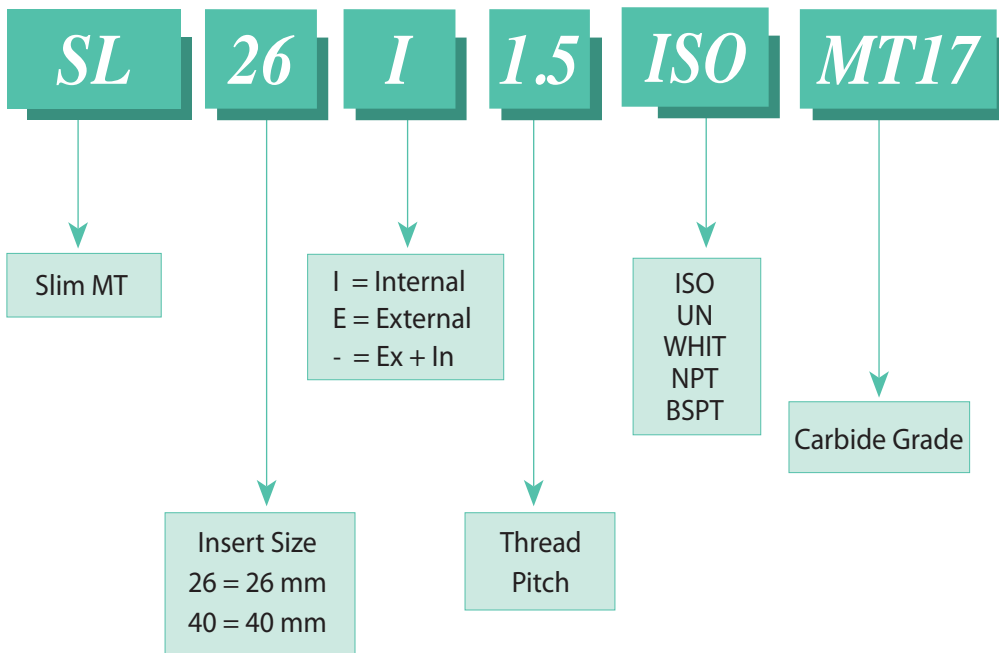

### Toolholders

