

Multi Insert Toolholders

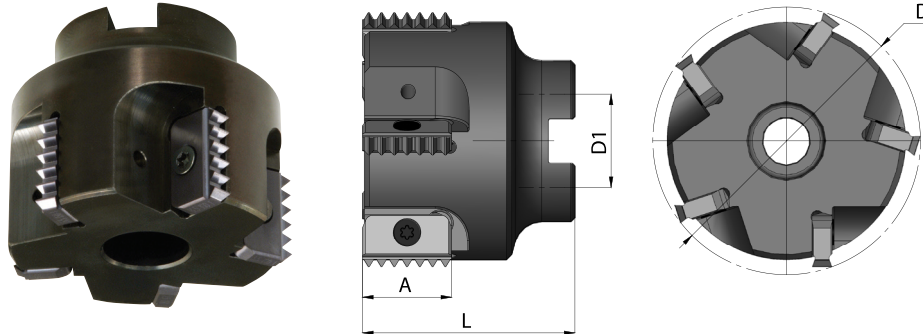

Ordering Code	A	D	D1	L	No. of Inserts	Insert Screw	Torx Key
SR0063C21-5	21	63	22	50	5	S21	K21
SR0063C30-4	30	63	22	50	4	S30	K30
SR0080D30-4	30	80	27	55	4	S30	K30
SR0100D30-4	30	100	32	60	4	S30	K30
SR0100D30-8	30	100	32	60	8	S30	K30
SR0080D40-4	40	80	27	65	4	S40	K40
SR0100E40-4	40	100	32	70	4	S40	K40
SR0100E40-6	40	100	32	70	6	S40	K40

Order example: SR0080D30-4

External Multi Insert Toolholder



Demonstration

- Reduced machining time
- Optimal coolant supply

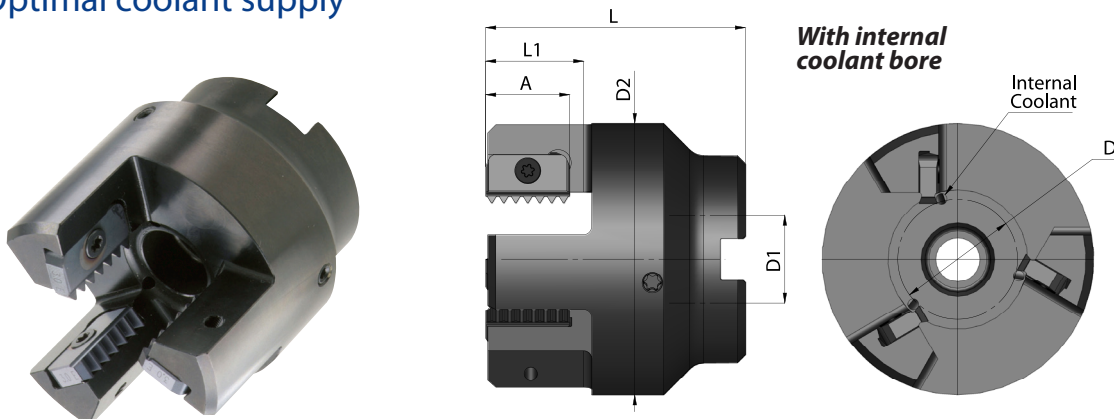

Ordering Code	A	D	D1	D2	L	L1	No. of Inserts	Insert Screw	Torx Key
SLE0020D21-3	21	20	22	58	65	25	3	S21	K21
SLE0030D21-3	21	30	22	68	65	25	3	S21	K21
SLE0045E21-4	21	45	27	83	70	25	4	S21	K21

Order example: SLE0030D21-3

Product Identification

Mill-Thread Toolholders Ordering Codes

