

## D-Thread Mill-Thread Inserts & Toolholders for machining deep threads

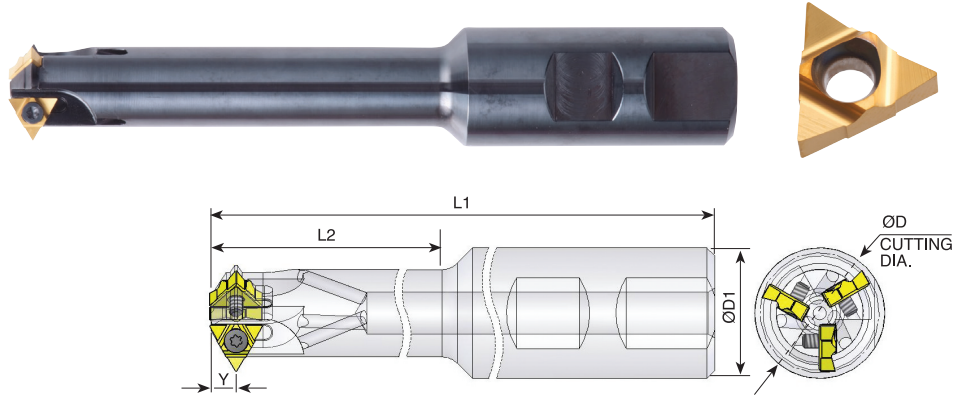

Ordering Code	Insert Size		Y	D	D1	L1	L2	No. of Inserts	Insert Screw	Torx Key
	L	I.C								
*SR0015M11U	11U	1/4U	5	14.8	16	150	55	1	SE11	K11
**SR0021M11U	11U	1/4U	5	20.6	25	150	65	2	SE11	K11
SR0023M11U	11U	1/4U	5	23	25	150	88	3	SE11	K11

\* Pitch limitations: for partial 60° - INT. - 10-9 TPI, EX. -12 - 10 TPI; for partial 55° - 12 - 9 TPI

\*\* Pitch limitations: for partial 60° - INT. - 10-8 TPI, EX. -12 - 9 TPI; for partial 55° - 12 - 9 TPI

### Partial 60° Size 11U

Ordering Code		Pitch	
		mm	TPI
11U 60D	INT.	2.5 - 4.0	10 - 6
	EX.	2.0 - 3.0	12 - 8
11U 60D-18-12	INT.	1.5 - 2.0	18 - 12
	EX.	1.25 - 1.75	20 - 14

Coated Grade: BMA

### Partial 55° Size 11U

Ordering Code		Pitch TPI
11U 55D	INT./EX.	12 - 7

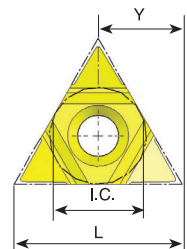

## Product Identification - Ordering Codes

### Spiral Mill - Thread Inserts

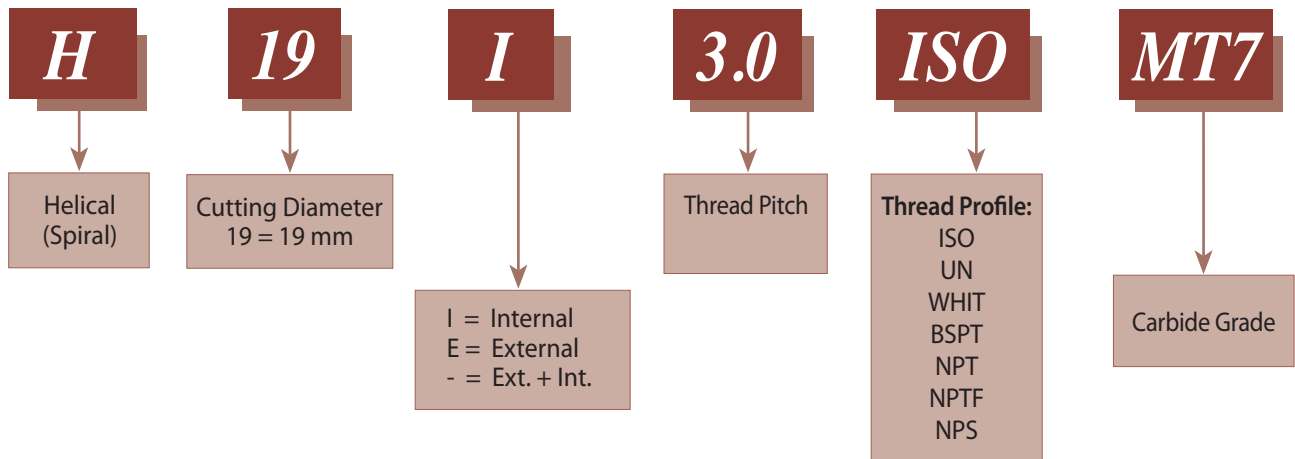

### Spiral Mill - Thread Toolholders

