

## Steel Toolholders

With internal coolant

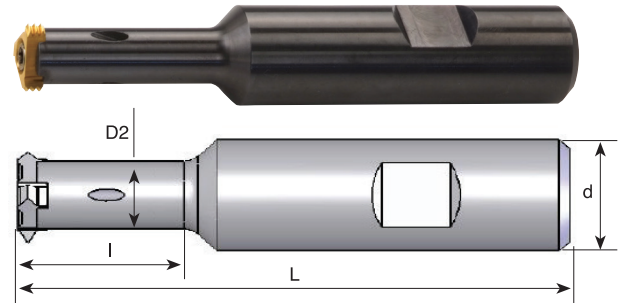

Tool No.	Ordering Code	Insert Type	d	D2	l	L	Insert Screw	Torx Key
H1	<b>SRC 1210 E</b>	C10	12	7.3	19	70	S5	K5
H1.1	<b>SRC 1210 F</b>		12	8.0	25	80	S5	K5
H2	<b>SRC 1610 G</b>		16	7.3	19	90	S5	K5
H3	<b>SRC 1212 E</b>	C12, S17	12	9.0	25	70	S10	K10
H3.1	<b>SRC 1212 G</b>		12	10.0	40	90	S10	K10
H4	<b>SRC 1612 G</b>		16	9.0	25	90	S10	K10
H5	<b>SRC 1612 H</b>		16	9.0	35	100	S10	K10
H5.1	<b>SRC 1618 F</b>	C18, S20	16	12.0	25	80	S16	K16
H5.2	<b>SRC 1618 G</b>		16	12.0	40	90	S16	K16
H6	<b>SRC 1618 H</b>		16	13.8	48	100	S16	K16
H7	<b>SRC 2018 H</b>		20	13.8	32	100	S16	K16
H8	<b>SRC 2018 J</b>		20	13.8	48	110	S16	K16
H9	<b>SRC 2018 L</b>	20	13.8	74	140	S16	K16	
H10	<b>SRC 2525 J</b>	C25	25	17.5	45	115	S27	K27
H11	<b>SRC 2525 M</b>		25	17.5	80	150	S27	K27
H12	<b>SRC 2035 K</b>	S35	20	22.0	44	130	S33	K33
H13	<b>SRC 2535 H</b>		25	22.0	40	100	S33	K33
H14	<b>SRC 2535 K</b>		25	22.0	60	130	S33	K33

## **Product Identification - Ordering Codes** **CMT Toolholders**

